

Parts Catalog

MODEL	PRODUCT CODE
FB460V-X	316701A
FB460V-X	FB460V-AS00, BS00, CS00

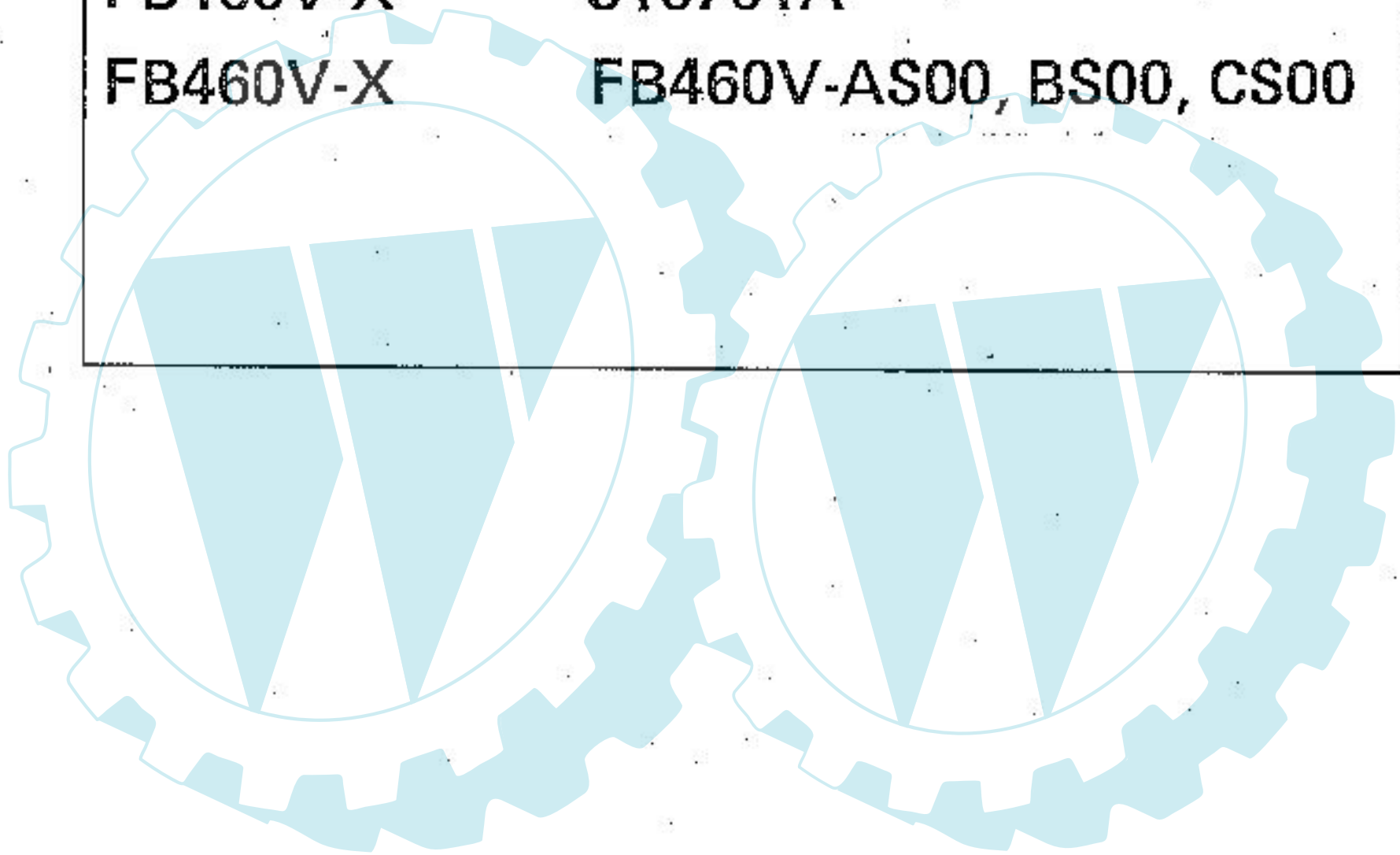

© KAWASAKI HEAVY INDUSTRIES, LTD.
ENGINE DIVISION
870730 Printed in Japan

FB460V-X 316701A

FB460V-X FB460V-AS00,BS00,CS00

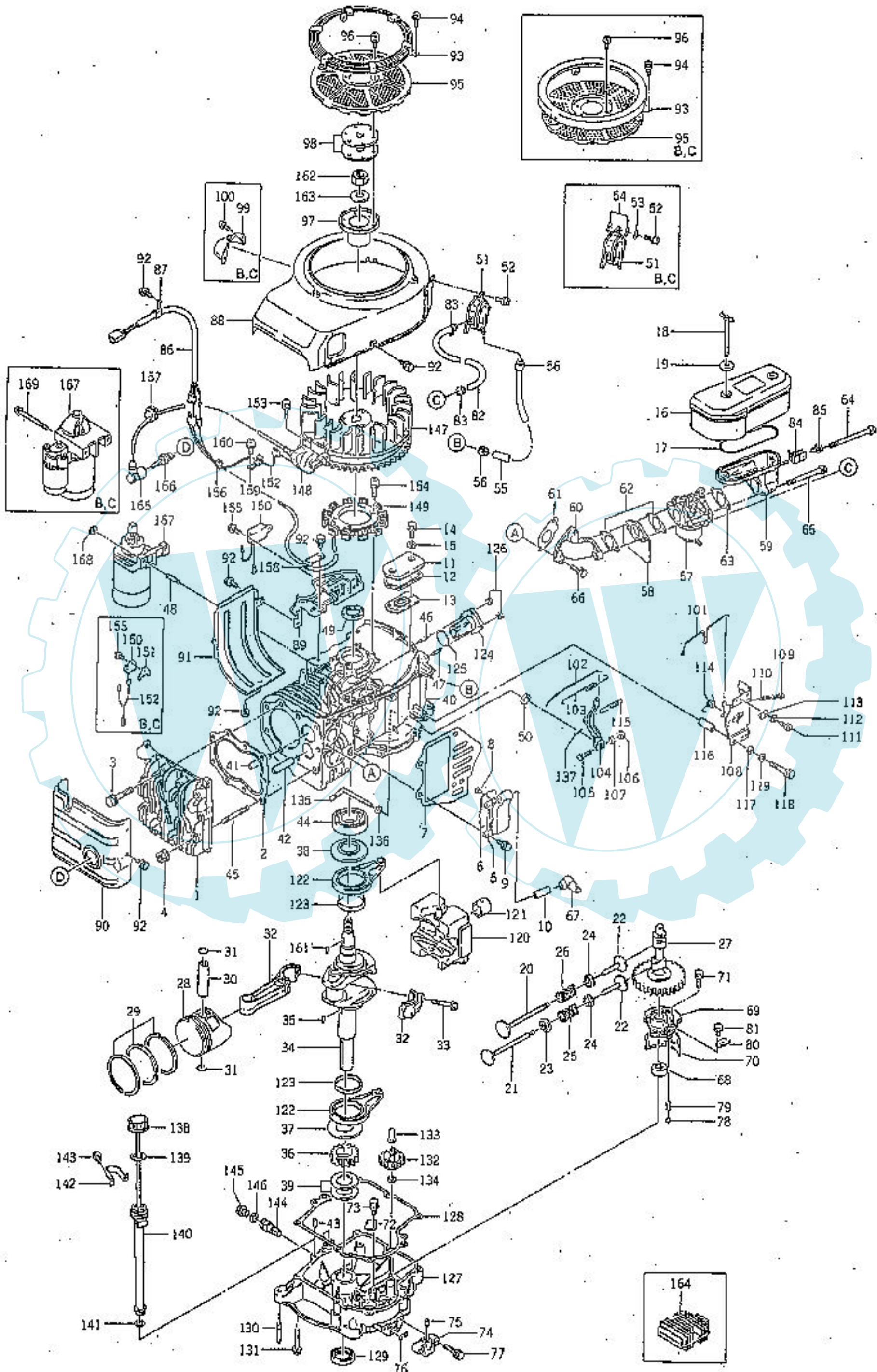

FB460V-X 316701A (A)
 FB460V-X FB460V-AS00,BS00,CS00(A,B,C)

Ref.No.	Part No.	Part Name	Quantity			Remarks
			A	B	C	
1	11001-2076	HEAD, cylinder	1	1		
	11001-2102	HEAD, cylinder			1	
2	11004-2079	GASKET, head	1	1	1	
3	130G1055	BOLT (10x55)	6	6	6	
4	92015-2115	NUT	3	3	3	
5	49108-2011	COVER, valve chamber	1	1	1	
6	14025-2143	COVER	1	1	1	
7	11009-2502	GASKET	1	1	1	
8	314405-3092A	SCREW	2	2	2	
9	130G0616	BOLT (6x16)	4	4	4	
10	92059-2142	TUBE	1	1	1	
11	14025-2040	COVER	1	1	1	
12	11009-2339	GASKET	1	1	1	
13	14069-2062	BREATHER	1	1	1	
14	315501-5381A	BOLT	2	2	2	
15	312200-7415-02	GASKET	2	2	2	
16	11010-2222	AIR FILTER ASSY	1			Fig. A-1
	11010-2291	AIR FILTER ASSY		1	1	Fig. A-1
17	11009-2443	GASKET	1	1	1	
18	92002-2230	BOLT	2	2	2	
19	92022-2179	WASHER	2			
	92022-2220	WASHER		2	2	
20	12004-2076	VALVE, intake	1	1	1	
21	12005-2066	VALVE, exhaust	1	1	1	
22	12032-2058	TAPPET	2	2	2	
23	12039-2052	ROTATOR	1	1	1	
24	39108-2054	RETAINER, spring	2	2	2	
25	49078-2058	SPRING, valve	1	1	1	
26	49078-2059	SPRING, valve	1	1	1	
27	12044-2109	SHAFT, cam	1	1		
	12044-2148	SHAFT, cam			1	
28	13001-2084	PISTON	1	1	1	S.T.D
	13029-2019	PISTON	AR	AR	AR	O/S 0.25mm
	13029-2020	PISTON	AR	AR	AR	O/S 0.50mm
	13027-2001	PISTON	AR	AR	AR	O/S 0.75mm
29	13008-6001	PISTON RING SET	1	1	1	S.T.D
	13008-6002	PISTON RING SET	AR	AR	AR	O/S 0.25mm
	13008-6003	PISTON RING SET	AR	AR	AR	O/S 0.50mm
	13008-6004	PISTON RING SET	AR	AR	AR	O/S 0.75mm
30	13002-2066	PIN, piston	1	1	1	
31	92033-2066	RING, snap	2	2	2	
32	13251-6005	CONNECTING ROD ASSY	1	1	1	S.T.D

FB460V-X 316701A (A)
 FB460V-X FB460V-AS00,BS00,CS00(A,B,C)

Ref.No.	Part No.	Part Name	Quantity			Remarks
			A	B	C	
32	13251-6007	CONNECTING ROD ASSY	AR	AR	AR	U/S 0.50mm
33	315801-3245A	•BOLT, connecting rod	2	2	2	
34	49119-2115	CRANK SHAFT ASSY	1	1		
	49119-2133	CRANK SHAFT ASSY			1	
35	510A5100	KEY	1	1	1	
36	59056-2018	GEAR, helical	1	1		
	59056-2105	GEAR, helical			1	
37	92026-2156	SPACER	1	1	1	
38	92026-2164	SPACER	1	1	1	
39	92025-2145	SHIM	AR	AR	AR	t=1.18
	92025-2146	SHIM	AR	AR	AR	t=1.25
	92025-2147	SHIM	AR	AR	AR	t=1.32
	92025-2148	SHIM	AR	AR	AR	t=1.39
	92025-2149	SHIM	AR	AR	AR	t=1.46
	92025-2150	SHIM	AR	AR	AR	t=1.53
	92025-2151	SHIM	AR	AR	AR	t=1.60
	92025-2152	SHIM	AR	AR	AR	t=1.67
	92025-2153	SHIM	AR	AR	AR	t=1.74
40	49120-6001	CRANK CASE COMP	1			
	49120-6025	CRANK CASE COMP		1	1	
41	49002-2070	•GUIDE, valve (IN)	1	1	1	
42	49002-2071	•GUIDE, valve (EX)	1	1	1	
43	551A0814	PIN, dowel	2			
	92043-2111	PIN		2		
	92043-1263	PIN			2	
44	601A6207	BEARING, ball (6207)	1	1	1	
45	92004-2082	STUD	3	3	3	
46	171G0612	STUD	2			
47	92004-2083	STUD	2	4	4	
48	172G0822	STUD	2			
49	92049-2096	SEAL, oil	1	1	1	
50	92049-2097	SEAL, oil	1	1	1	
51	49040-2058	FUEL PUMP ASSY	1	1	1	Fig. P-1
52	130B0610	BOLT (6x10)	2			
	130B0614	BOLT (6x14)		2	2	
53	311509-3595-00	WASHER		2	2	
54	92022-553	WASHER		4	4	
55	705A061000	TUBE, braid	1	1	1	λ=65mm
56	317196-6812-00	CLIP	2	2	2	
57	15001-2382	CARBURETOR ASSY	1			Fig. C-1
	15001-2425	CARBURETOR ASSY		1		Fig. C-1
	15001-2720	CARBURETOR ASSY			1	Fig. C-1
58	16073-2091	INSULATOR	1	1	1	

FB460V-X 316701A (A)
 FB460V-X FB460V-AS00,BS00,CS00(A,B,C)

Ref.No.	Part No.	Part Name	Quantity			Remarks
			A	B	C	
59	16060-2108	PIPE, intake	1	1	1	
60	16060-2109	PIPE, intake	1	1	1	
61	11009-2342	GASKET	1	1	1	
62	11009-2343	GASKET	2	2	2	
63	11009-2344	GASKET	1	1	1	
64	92002-2254	BOLT	1	1	1	
65	92002-2253	BOLT	1	1	1	
66	130G0825	BOLT (8x25)	2	2	2	
67	59071-2062	JOINT	1	1	1	
68	16082-2057	OIL PUMP ASSY	1	1	1	
69	16142-6001	PUMP COVER COMP	1	1	1	
70	49065-2056	FILTER, oil	1	1	1	
71	130G0825	BOLT (8x25)	3	3	3	
72	13169-2359	PLATE	1	1	1	
73	130B0508	BOLT (5x8)	1	1	1	
74	14025-2145	COVER	1	1	1	
75	352101-9145A	PLUG	1	1	1	
	92066-2102	PLUG			1	
76	92055-2063	O-RING	1	1	1	
77	130B0830	BOLT (8x30)	2	2	2	
78	600A1000	BALL, steel	1	1	1	
79	92081-2216	SPRING	1	1	1	
80	13169-2360	PLATE	1	1	1	
81	130B0610	BOLT (6x10)	1	1	1	
82	705A061000	TUBE, braid	1	1	1	∅=210mm
83	317196-6812-00	CLIP	2	2	2	
84	92037-2019	CLAMP	1	1	1	
85	224B0508	SCREW (5x8)	1	1	1	
86	26001-2113	HARNESS	1	1	1	
87	313646-8161-00	CLAMP	1	1		
88	59066-2264-9H	HOUSING, fan	1			
	59066-2294-9H	HOUSING, fan		1	1	
89	59066-2238-9H	HOUSING, fan	1			
	59066-2295-9H	HOUSING, fan		1	1	
90	49089-2168-9H	SHROUD	1	1	1	
91	49089-2169-9H	SHROUD	1			
	49089-2199-9H	SHROUD		1	1	
92	130B0610	BOLT (6x10)	11	11		
	130G0610	BOLT (6x10)			11	
93	55020-2053	GUARD	1			
	55020-2060	GUARD		1	1	
94	130B0508	BOLT (5x8)	3	3	3	
95	14037-2084-9H	SCREEN	1			

FB460V-X 316701A (A)
 FB460V-X FB460V-AS00,BS00,CS00(A,B,C)

Ref.No.	Part No.	Part Name	Quantity			Remarks
			A	B	C	
95	14037-2104-9H	SCREEN		1	1	
96	224B0616	SCREW (6x16)	3	3	3	
97	11043-2163	BRACKET	1	1	1	
98	92025-2003	SHIM	AR	AR	AR	
99	14024-2028-9H	COVER		1	1	
100	234B0408	SCREW (4x8)		2	2	
101	16169-2074	LINK, choke	1	1	1	
102	16171-2001	LINK	1	1	1	
103	92081-2213	SPRING	1	1	1	
104	21187-2052	GOVERNOR ARM COMP	1	1	1	
105	92002-2269	BOLT	1	1	1	
106	311B0600	NUT (6mm)	1	1	1	
107	411B0600	WASHER	1	1	1	
108	49113-2058	CONTROL PANEL ASSY	1	1		
	49113-2065	CONTROL PANEL ASSY			1	
109	214B0425	SCREW (4x25)	1	1	1	
110	314401-5321B	SPRING	1	1	1	
111	315501-5381A	BOLT	1	1		
	310701-1225A	BOLT			1	
112	411B0500	WASHER	1	1		
113	92037-2020	CLAMP	1	1	1	
114	92081-2316	SPRING	1	1	1	
115	92081-2214	SPRING	1	1		
	39129-2010	SPRING			1	
116	92027-2071	COLLAR	2	2	2	
117	311509-3595-00	WASHER	2	2	2	
118	112B0650	BOLT (6x50)	2	2	2	
119	461F0600A	WASHER, spring	2	2	2	
120	13042-6005	WEIGHT COMP	1			
	13042-6006	WEIGHT COMP		1	1	
121	92141-2007	BEARING, plain	1			
	92141-2097	BEARING, plain		1	1	
122	46102-6001	ROD ASSY	2	2	2	
123	92141-2094	BEARING, plain	2	2	2	
124	13107-2082	SHAFT	1			
	13107-2091	SHAFT		1	1	
125	92055-2062	O-RING	1			
	92055-2072	O-RING		1	1	
126	92015-1193	NUT	4	4	4	
127	49015-6001	CRANK CASE COVER COMP	1	1	1	
128	11009-2337	GASKET	1	1	1	
129	92049-2104	SEAL, oil	1	1	1	
130	92004-2081	STUD	2			

FB460V-X 316701A (A)
 FB460V-X FB460V-AS00,BS00,CS00(A,B,C)

Ref.No.	Part No.	Part Name	Quantity			Remarks
			A	B	C	
131	130G0845	BOLT (8x45)	8	8	8	
132	49110-2067	GOVERNOR ASSY	1	1	1	
133	42036-2060	SLEEVE	1	1	1	
134	314401-5139A	WASHER	1	1	1	
135	39003-2062	ARM, pivot	1	1	1	
136	410B0600	WASHER	1	1	1	
137	554A0600	PIN, snap	1	1	1	
138	52005-2058	GAUGE	1	1	1	
139	11009-2346	GASKET	1	1	1	
140	59231-2059	FILLER	1	1	1	
141	670D2016	O-RING	1	1	1	
142	92037-2160-9H	CLAMP	1	1	1	
143	130B0508	BOLT (5x8)	1	1	1	
144	59071-2063	JOINT	1	1		
	59071-2074	JOINT			1	
145	92066-2092	PLUG	1	1	1	
146	317370-7883-00	GASKET	1	1	1	
147	21193-2001	FLYWHEEL COMP	1	1	1	
148	21121-2008	COIL, ignition	1	1	1	
149	59031-2003	COIL, charging	1	1	1	
150	21119-2007	IGNITER	1			
	21119-2095	IGNITER		1	1	
151	310702-8137A	BRACKET		1	1	
152	26011-2065	WIRE, lead	1			
	26011-2119	WIRE, lead		1	1	
153	130B0525	BOLT (5x25)	2	2	2	
154	224B0620	SCREW (6x20)	4	4	4	
155	234B0408	SCREW (4x8)	2	1	1	
156	92071-2099	GROMMET	1	1	1	
157	92071-2100	GROMMET	1	1	1	
158	92037-2158	CLAMP	1	1	1	
159	311901-8161A	CLAMP	1	1	1	
160	234B0408	SCREW (4x8)	1	1	1	
161	510A5100	KEY	1	1	1	
162	314G1800	NUT (18mm)	1	1	1	
163	92022-2178	WASHER	1	1	1	
164	21066-2004	REGULATOR, voltage	1	1	1	
165	21130-2060	CAP, plug	1	1	1	
166	92070-2072	PLUG, spark (NGK BMR4A)	1	1	1	
167	21163-2065	ELECTRIC STARTER ASSY	1			Fig. S-1
	21163-2070	ELECTRIC STARTER ASSY		1	1	Fig. S-2
168	92015-1143	NUT	2			
169	92002-2278	BOLT		2	2	

Fig. A-1 AIR FILTER

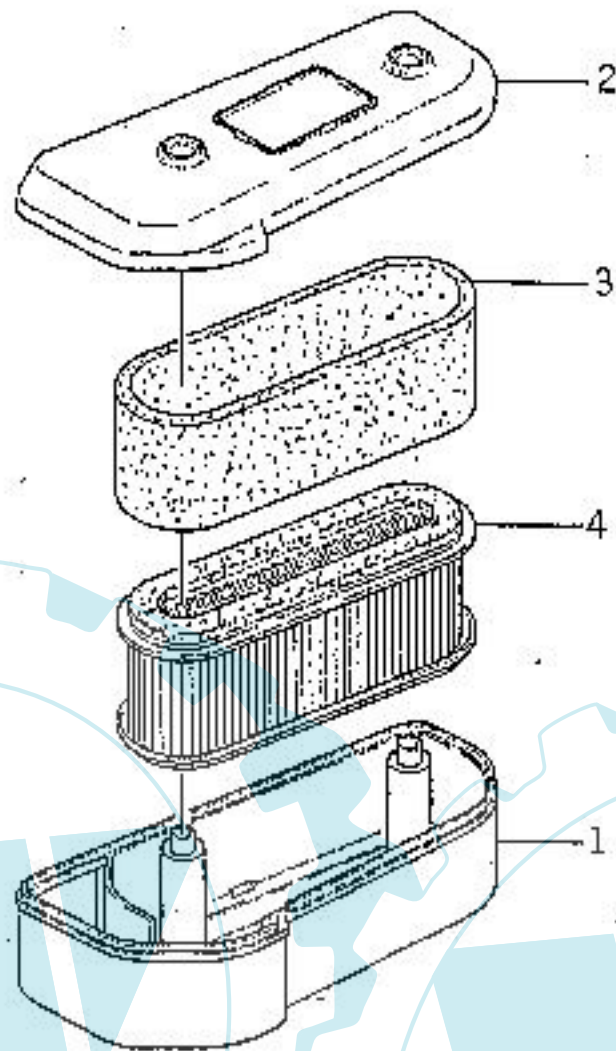

Ref.No.	Part No.	Part Name	Quantity			Remarks
			A	B	C	
	11010-2222	AIR FILTER ASSY	1			
	11010-2291	AIR FILTER ASSY		1	1	
A-1- 1	11011-2016	•CASE, air filter	1			
	11011-2174	•CASE, air filter		1	1	
A-1- 2	11012-2083	•CAP, air filter	1			
	11012-2192	•CAP, air filter		1	1	
A-1- 3	11013-2020	•ELEMENT, air filter	1	1	1	
A-1- 4	11013-2021	•ELEMENT, air filter	1	1	1	

Fig. C-1 CARBURETOR

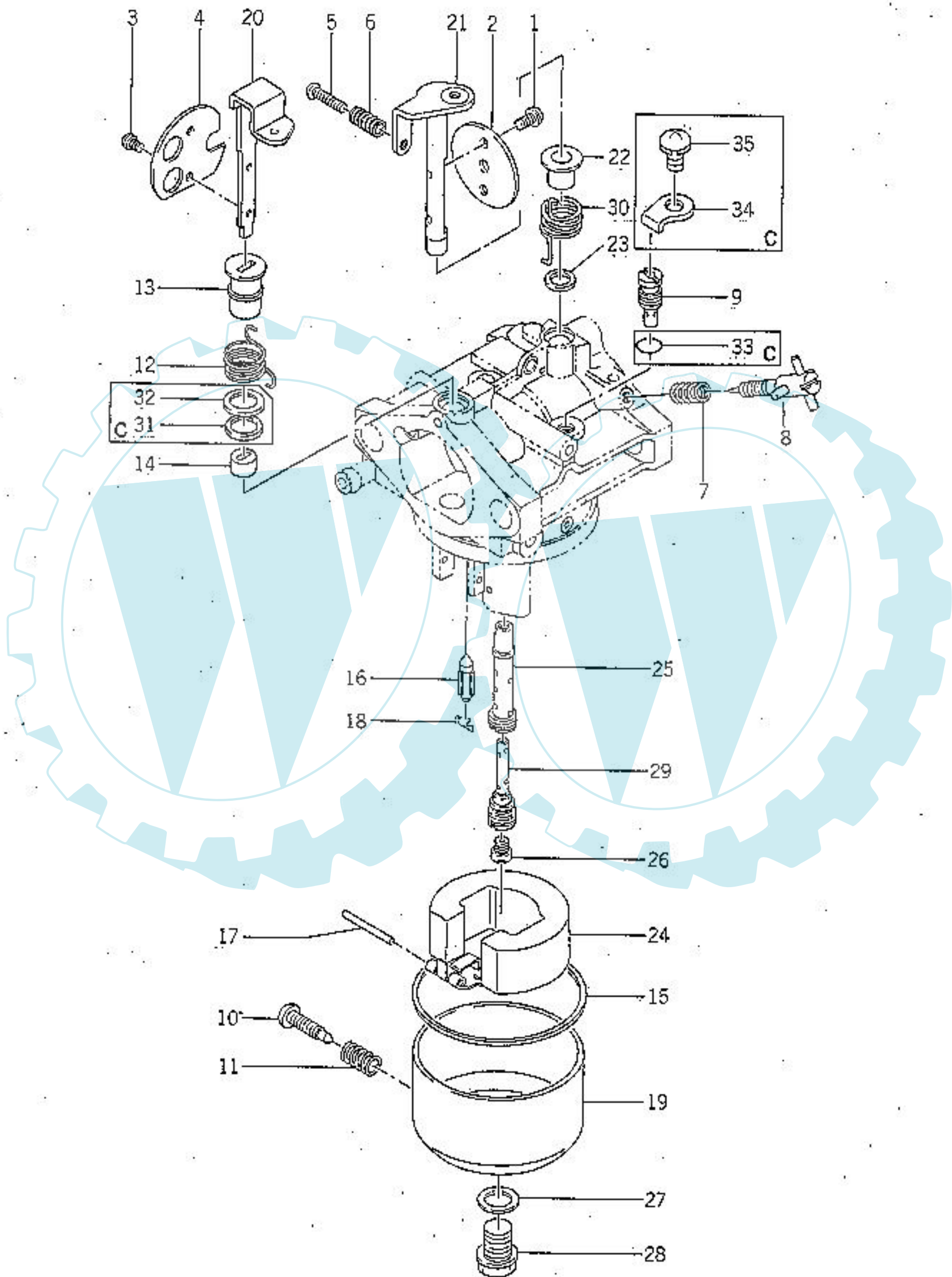
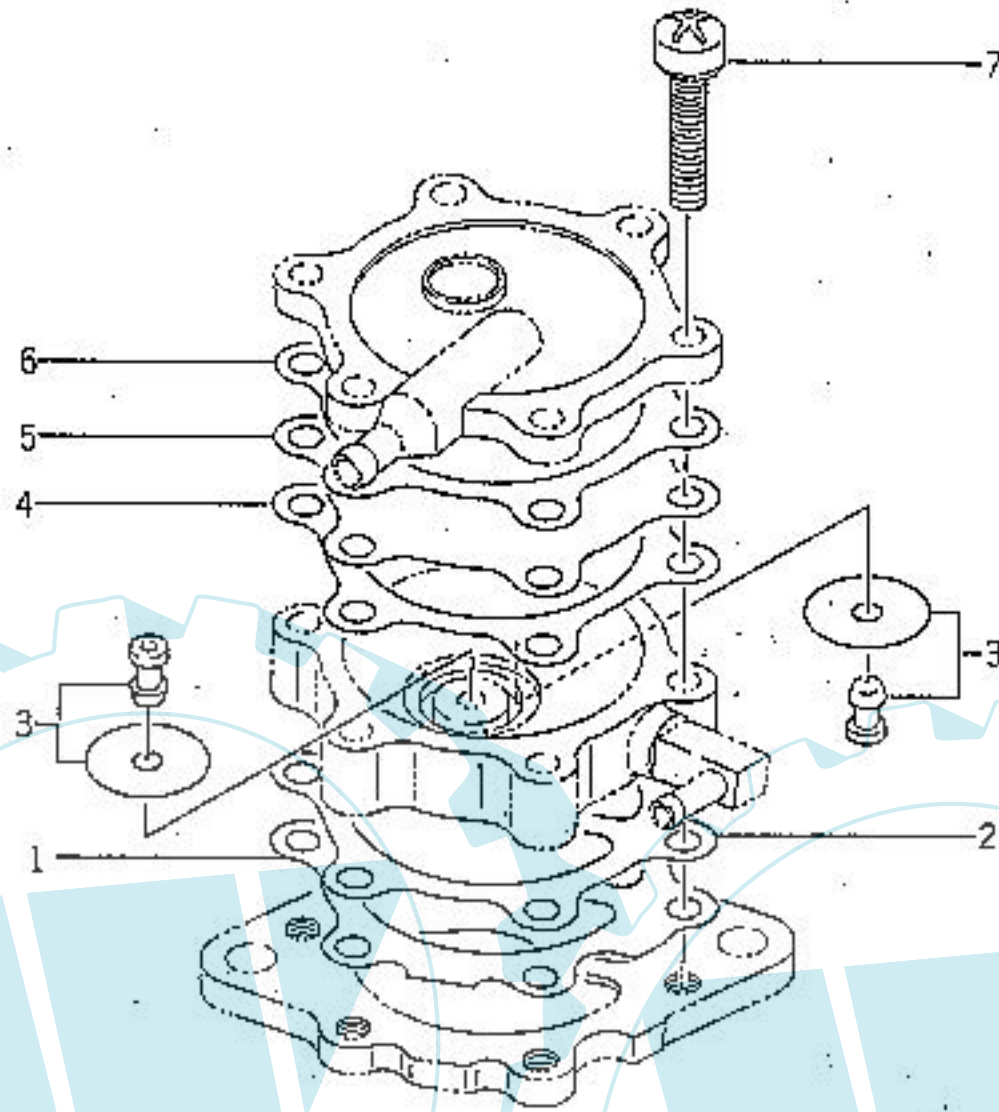

Fig. C-1 CARBURETOR

Ref.No.	Part No.	Part Name	Quantity			Remarks
			A	B	C	
	15001-2382	CARBURETOR ASSY	1			
	15001-2425	CARBURETOR ASSY		1		
	15001-2720	CARBURETOR ASSY			1	
C-1- 1	316550-6137A	•SCREW	2	2	2	
C-1- 2	16025-2005	•VALVE, throttle (#100)	1			
	16025-2101	•VALVE, throttle (#120)		1	1	
C-1- 3	314572-6137A	•SCREW	2	2	2	
C-1- 4	16126-2011	•VALVE, choke	1			
	16126-2105	•VALVE, choke		1	1	
C-1- 5	92009-2079	•SCREW	1	1	1	
C-1- 6	313650-6108-00	•SPRING	1	1	1	
C-1- 7	312750-6116-00	•SPRING	1	1	1	
C-1- 8	16014-2055	•SCREW, adjuster	1	1	1	
C-1- 9	317490-6112-00	•JET, pilot (#47.5)	1			
	319201-6112-02	•JET, pilot (#62.5)		1		
	92064-2059	•JET, pilot (#65)			1	
C-1-10	315470-6133A	•SCREW, drain	1	1	1	
C-1-11	313122-6116-00	•SPRING	1	1	1	
C-1-12	92081-2078	•SPRING	1	1		
	92144-2160	•SPRING			1	
C-1-13	92027-2026	•RING	1	1		
	92143-2007	•RING			1	
C-1-14	314598-6138A	•RING	1	1	1	
C-1-15	313650-6128-00	•GASKET	1	1	1	
C-1-16	16030-2021	•VALVE, needle	1	1	1	
	16030-2067	•VALVE, needle		1	1	
C-1-17	314499-6127A	•PIN, float	1	1	1	
C-1-18	314595-6134A	•CLIP	1	1		
	315721-6134A	•CLIP			1	
C-1-19	16020-2051	•CHAMBER, float	1	1		
	16020-2094	•CHAMBER, float			1	
C-1-20	16041-2010	•SHAFT, choke	1	1	1	
C-1-21	16041-2009	•SHAFT, throttle	1	1	1	
C-1-22	92027-2025	•RING	1	1	1	
C-1-23	316626-6206A	•SEAL	1	1	1	
C-1-24	315801-6126A	•FLOAT	1	1		
	16031-2066	•FLOAT			1	
C-1-25	49121-2010	•NOZZLE, main (#6A)	1			
	49121-2077	•NOZZLE, main (#13A)		1	1	
C-1-26	92063-2010	•JET, main (#112.5)	1	1	1	
C-1-27	318190-6159-00	•WASHER	1	1	1	
C-1-28	314486-6143A	•BOLT	1	1	1	
C-1-29	49123-2016	•HOLDER, main jet	1	1		
	49123-2058	•HOLDER, main jet			1	
C-1-30	92081-2077	•SPRING	1	1	1	
C-1-31	92093-2069	•SEAL			1	
C-1-32	92022-2242	•WASHER			1	
C-1-33	16038-024	•GASKET			1	
C-1-34	13183-2252	•PLATE			1	
C-1-35	92009-2244	•SCREW			1	

Fig. P-1 FUEL PUMP



Ref.No.	Part No.	Part Name	Quantity			Remarks
			A	B	C	
	49040-2058	FUEL PUMP ASSY	1	1	1	
P-1- 1	11009-2353	•GASKET	1	1	1	
P-1- 2	43028-2052	•DIAPHRAGM	1	1	1	
P-1- 3	49116-2051	•VALVE ASSY	2	2	2	
P-1- 4	11009-2352	•GASKET	1	1	1	
P-1- 5	43028-2051	•DIAPHRAGM	1	1	1	
P-1- 6	11009-2351	•GASKET	1	1	1	
P-1- 7	92009-2212	•SCREW	6	6	6	

Fig. S-1 ELECTRIC STARTER

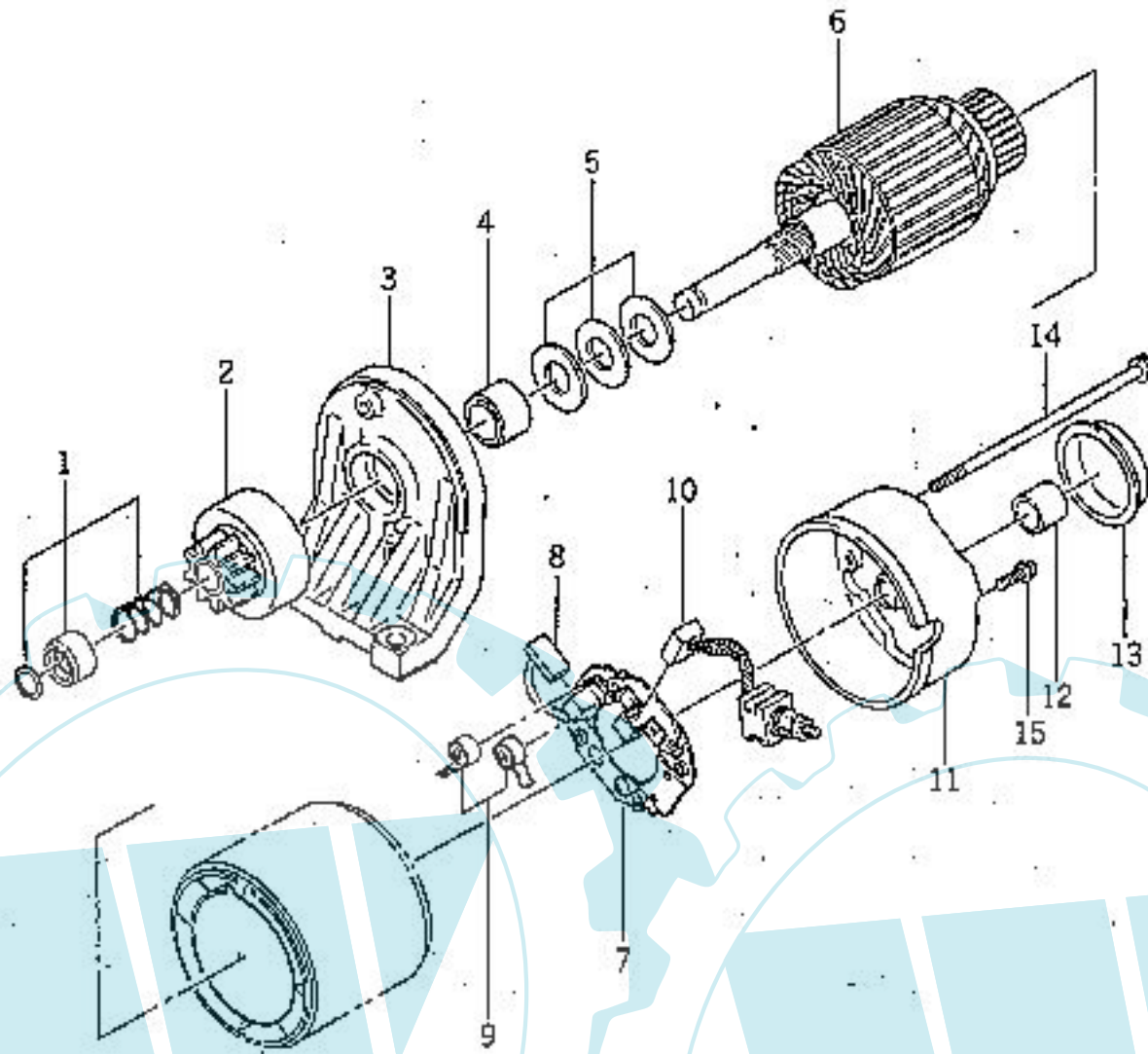

Ref.No.	Part No.	Part Name	Quantity		Remarks
			A	B	
	21163-2065	ELECTRIC STARTER ASSY	1		
S-1-1	317103-8331B	•PINION STOPPER SET	1		
S-1-2	317221-8312A	•CLUTCH ASSY	1		
S-1-3	16146-2063	•COVER ASSY (F)	1		
S-1-4	317221-8348-00	•METAL, front cover	1		
S-1-5	92022-2187	•WASHER KIT	1		
S-1-6	21080-2051	•ARMATURE	1		
S-1-7	14079-2053	•BRUSH HOLDER ASSY	1		
S-1-8	319203-8326-00	•BRUSH (-)	1		
S-1-9	21040-2051	•SPRING, brush	3		
S-1-10	319203-8325-00	•BRUSH (+)	2		
S-1-11	16146-2064	•COVER ASSY (R)	1		
S-1-12	317299-8356-01	•METAL, rear cover	1		
S-1-13	317224-8375A	•COVER, dust	1		
S-1-14	92002-2241	•BOLT	2		
S-1-15	2328 0412	•SCREW (4x12)	2		

Fig.S-2 ELECTRIC STARTER

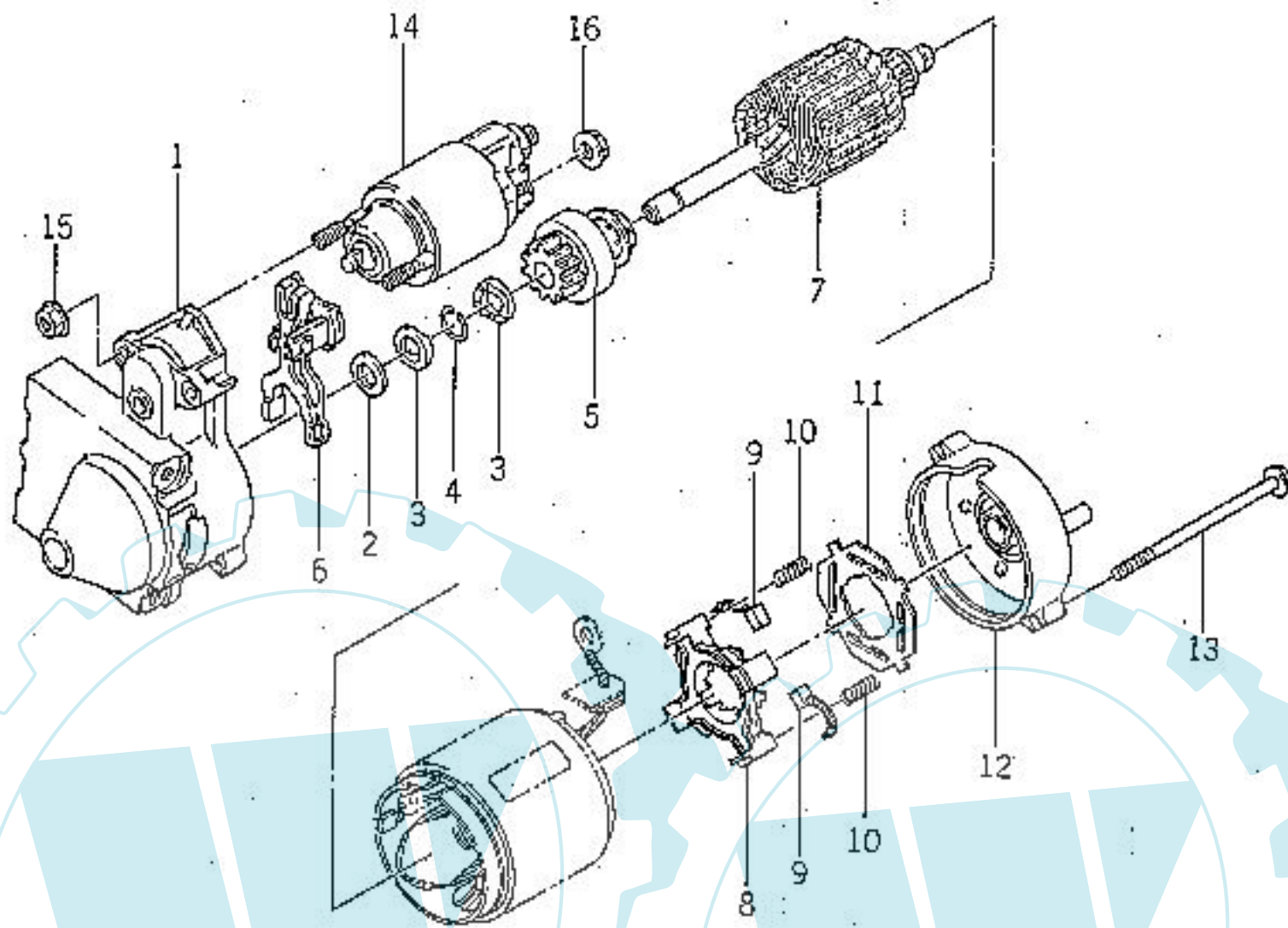

Ref.No.	Part No.	Part Name	Quantity			Remarks
			A	B	C	
	21163-2070	ELECTRIC STARTER ASSY		1	1	
S-2-1	16146-2076	COVER ASSY		1	1	
S-2-2	92022-2218	WASHER		1	1	
S-2-3	32085-2066	STOPPER		2	2	
S-2-4	92033-2081	RING, snap		1	1	
S-2-5	13081-2085	CLUTCH ASSY		1	1	
S-2-6	13168-2131	LEVER		1	1	
S-2-7	21080-2054	ARMATURE		1	1	
S-2-8	13091-2068	HOLDER, brush		1	1	
S-2-9	21039-2059	BRUSH		4	4	
S-2-10	21040-2052	SPRING, brush		4	4	
S-2-11	16073-2098	INSULATOR		1	1	
S-2-12	16146-2077	COVER ASSY		1	1	
S-2-13	92002-2277	BOLT		2	2	
S-2-14	27010-2122	SWITCH ASSY		1	1	
S-2-15	92015-2146	NUT		2	2	
S-2-16	92015-2147	NUT		1	1	