

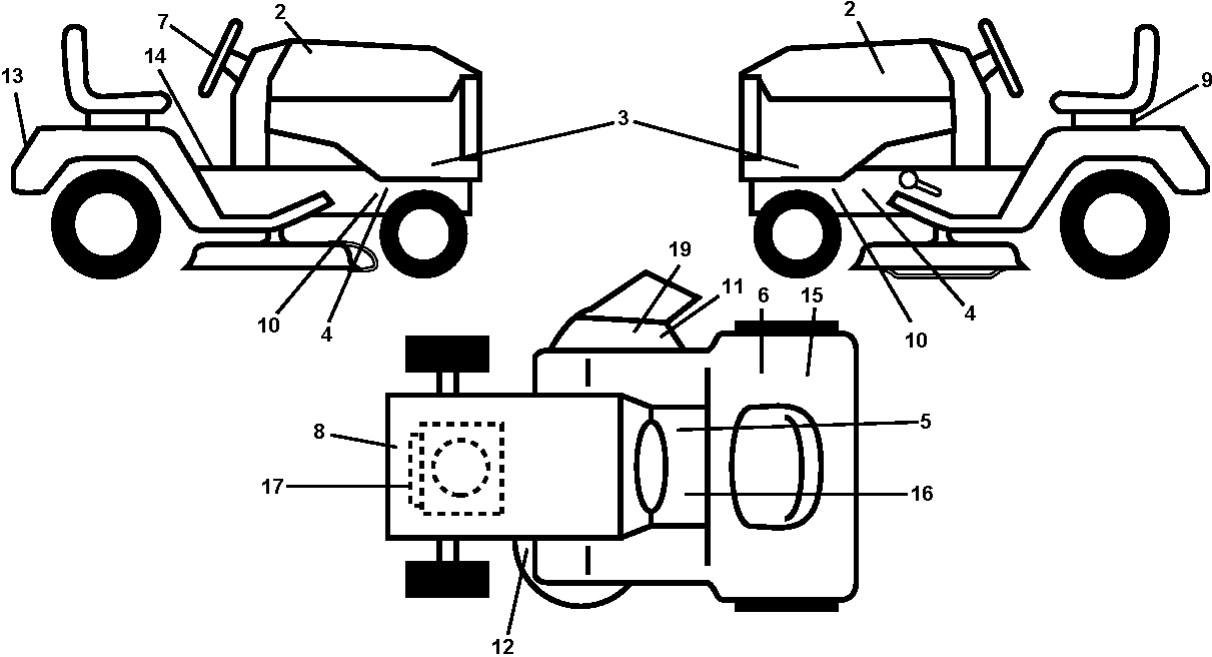

SPARE PARTS LIST

TRACTORS/RIDE MOWERS

P145107HP, 96041001504, 2010-03



AUFKLEBER

P145107HP, 96041001504, 2010-03

Referenz	Teile Nr	Beschreibung	Bemerkung:	ANZ KIT
2	532 43 16-16	Folie		1
3	532 40 86-35	Folie		1
4	532 15 97-36	Folie		1
5	532 14 08-37	Folie		1
6	532 18 04-32	Folie		1
7	532 42 57-58	Folie		1
8	532 19 68-41	Folie		1
9	532 14 50-05	Folie		1
10	532 18 56-51	Folie		1
11	532 19 63-57	DECALC."DANGER DEFLECTEUR"		1
12	532 16 03-96	Folie		1
13	532 40 86-36	Folie		1
14	532 40 03-89	AUFKLEBER		1
15	532 17 83-02	Folie		1
16	532 15 97-37	Folie		1
17	532 43 10-94	Folie		1
19	532 18 21-66	Folie		1
--	532 16 69-60	Folie		1
--	532 16 25-98	Folie		1
--	532 40 95-05	KISSEN		1
--	532 40 95-07	KISSEN		1

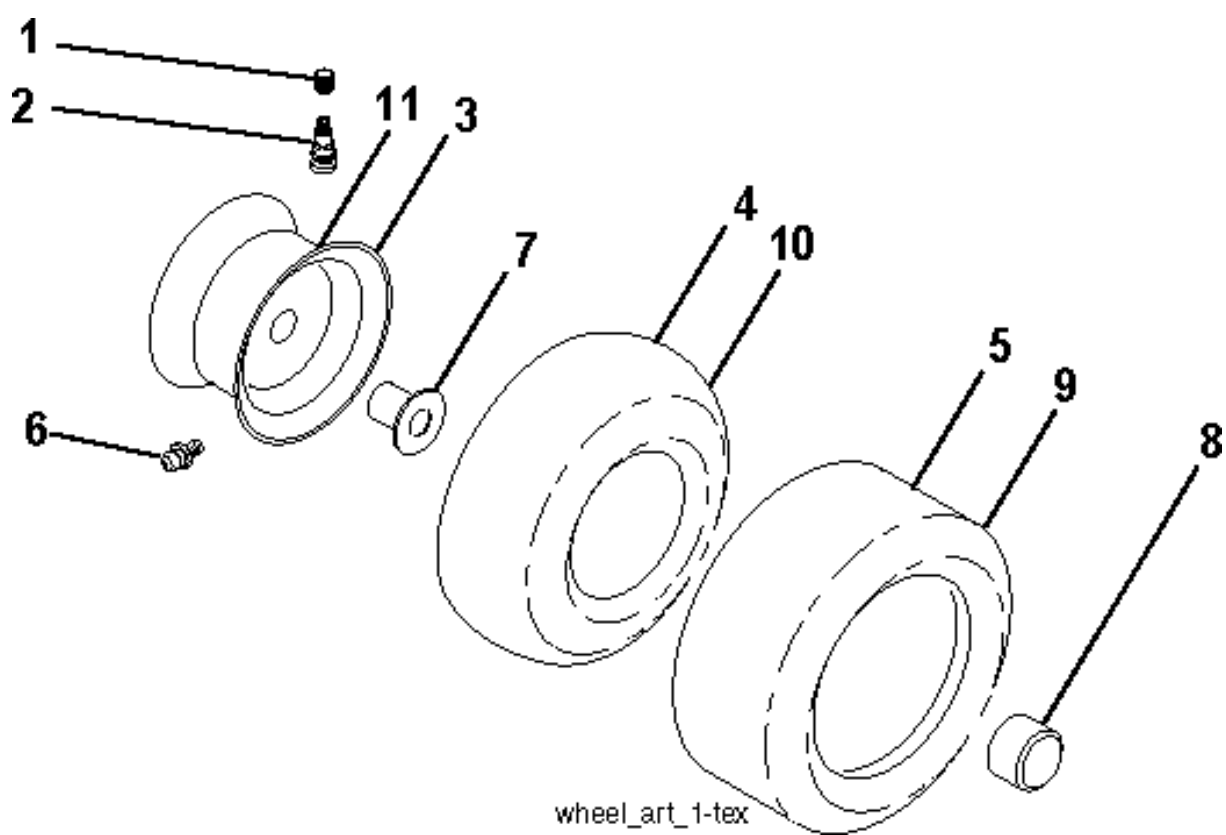

RÄDER & REIFEN

P145107HP, 96041001504, 2010-03

Referenz	Teile Nr	Beschreibung	Bemerkung:	ANZ KIT
1	532 05 91-92	CAP VALVE		1
2	532 06 51-39	NIPPEL		1
3	532 12 51-21	RIM, 6"		1
4	532 05 99-04	SCHLAUCH		1
5	532 10 62-22	REIFEN		1
6	532 12 49-57	NIPPEL		1
7	532 12 49-59	LAGER		1
8	532 17 50-39	RADKAPPE		1
9	532 13 84-68	REIFEN		1
10	532 12 49-26	SCHLAUCH		1
11	532 12 51-22	RIM, 8"		1
--	532 14 43-34	SEALING FOAM		1

T06S

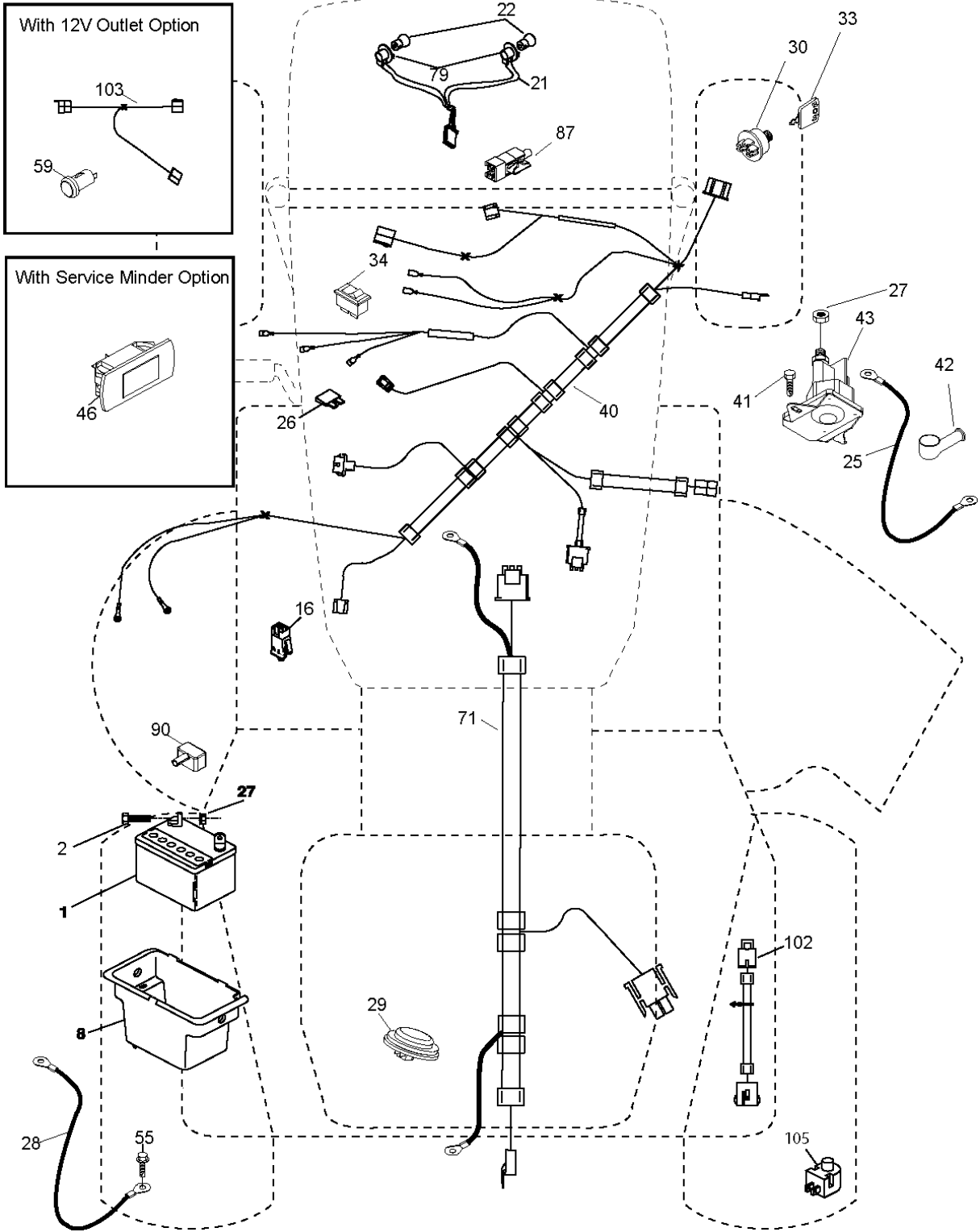

Referenz	Teile Nr	Beschreibung	Bemerkung:	ANZ KIT
1	532 16 34-65	BATTERIE		1
2	874 76 04-12	BOLZEN		1
8	532 19 32-28	KISTE		1
16	532 17 61-38	SWITCH INTERLOCK		1
21	532 40 02-52	KABEL		1
22	532 00 41-52	LAMPE		1
25	532 41 28-94	CABLE.STARTER.6GA.BL/R*SUBS/2*		1
26	532 17 51-58	SICHERUNG		1
27	873 51 04-00	MUTTER		1
28	532 19 88-85	KABEL		1
29	532 40 15-45	SCHALTER		1
30	532 19 33-50	ELEKTRONIKMODUL		1
33	532 41 19-35	TASTE		1
34	532 11 07-12	SCHALTER		1
40	532 40 10-98	KABEL		1
41	817 72 04-08	SCHRAUBE		1
42	532 13 15-63	DECKEL		1
43	532 19 25-07	ELEKTROMAGNET		1
55	817 06 05-12	SCHRAUBE		1
71	532 40 04-49	KABEL		1
79	532 17 52-42	HOLDER		1
87	532 19 78-02	SCHALTER		1
90	532 40 07-25	DECKEL		1
102	532 40 44-54	KABEL		1
105	532 40 75-68	SCHALTER		1

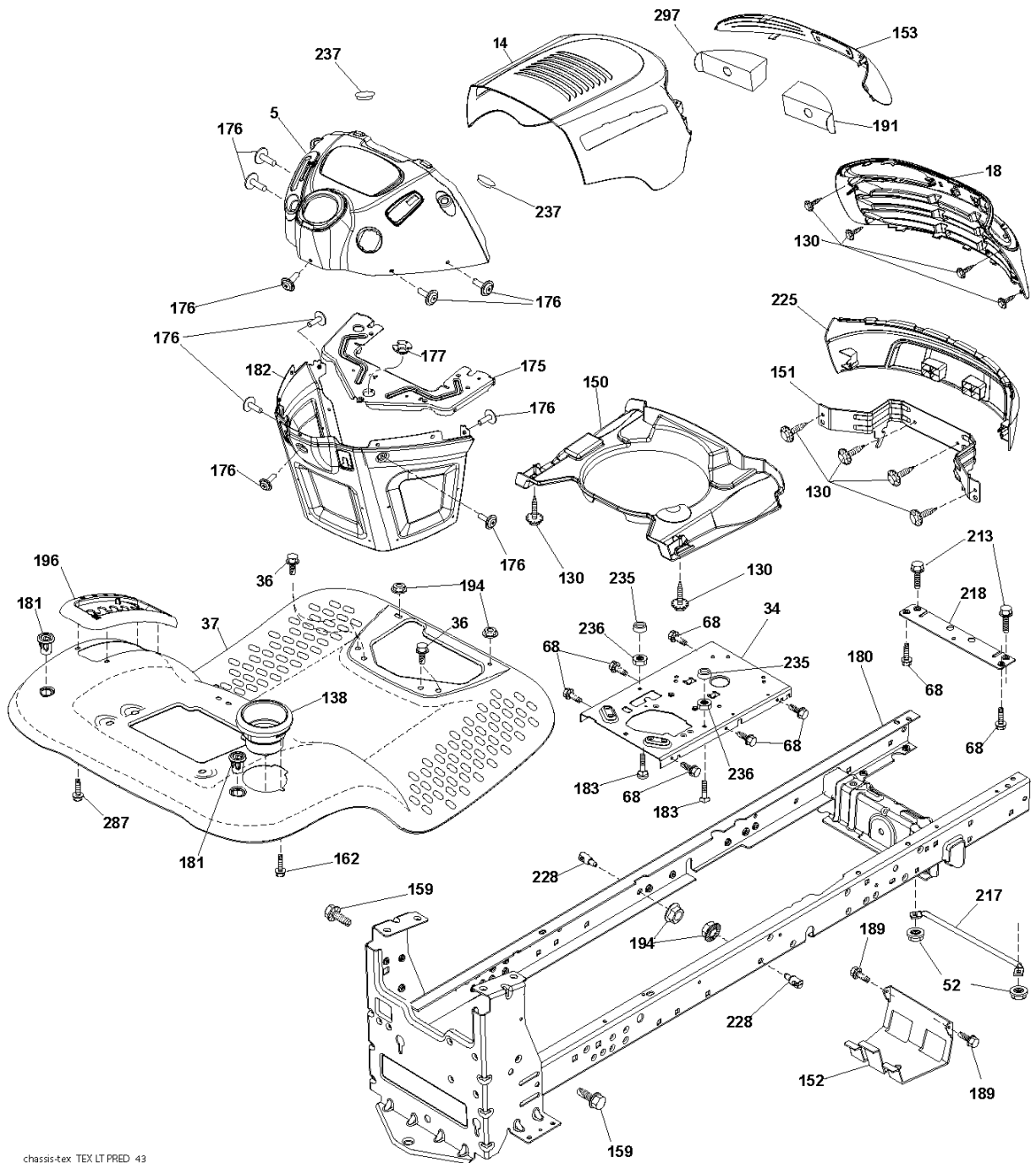

Referenz	Teile Nr	Beschreibung	Bemerkung:	ANZ KIT
5	532 40 95-97	SCHALTBRETT		1
14	532 40 95-98	HAUBE		1
18	532 42 65-11	GRILLE		1
34	532 19 61-25	PLATTE		1
36	817 06 05-12	SCHRAUBE		1
37	532 42 07-96	RADABDECKUNG		1
68	817 49 05-08	SCHRAUBE		1
130	532 41 63-58	SCHRAUBE		1
138	532 40 97-30	BEFESTIGUNG		1
150	532 40 83-10	LUFTLEITBLECH		1
151	532 18 75-68	HALTER		1
152	532 19 95-35	SCHIRM		1
153	532 40 97-40	LINSE		1
159	817 00 06-12	SCHRAUBE		1
162	532 14 24-32	SCHRAUBE		1
175	532 19 94-72	PLATTE		1
176	532 40 07-76	SCHRAUBE		1
177	532 19 52-28	BUSHING		1
180	532 19 54-57	RAHMEN		1
181	532 40 47-96	BUSHING		1
182	532 40 71-76	SCHALTBRETT		1
183	874 78 05-20	BOLZEN		1
189	817 00 05-12	SCHRAUBE		1
191	532 41 65-02	EINSATZ		1
194	873 90 05-00	MUTTER		1
196	532 41 45-81	BEFESTIGUNG		1
213	874 76 05-12	BOLZEN		1
217	532 40 91-67	STANGE		1
218	532 19 63-95	PLATTE		1
225	532 40 95-85	STOSSFÄNGER		1
228	532 19 51-61	GEWINDESTIFT		1
235	532 40 61-29	ABSTANDSSCHEIBE		1
236	873 93 05-00	MUTTER		1
237	532 40 37-04	STOPFEN		1
287	817 60 04-06	SCHRAUBE		1
297	532 40 18-27	LINSE		1

ANTRIEB

P145107HP, 96041001504, 2010-03

Referenz	Teile Nr	Beschreibung	Bemerkung:	ANZ KIT
1	000 00 00-00	W/O DESCRIPTION	Transaxle, TUFF TORQ K46 BT	1
2	532 12 35-83	TASTE		1
15	819 13 13-16	SCHEIBE		1
17	532 41 36-78	SRPING.BRAKE.K46.GREEN*SUBS/2*		1
29	532 40 38-06	STANGE		1
33	812 00 00-01	SPRENGRING		1
35	532 40 10-31	STANGE		1
42	532 12 48-72	PEDAL RUBBER		1
49	872 11 06-14	BOLZEN		1
50	532 19 43-27	RIEMENSCHLEIBE		1
51	873 90 06-00	MUTTER		1
52	532 19 43-26	RIEMENSCHLEIBE		1
56	532 13 09-69	RIEMEN		1
64	532 19 78-65	WELLE		1
73	874 49 05-44	SCHRAUBE		1
80	532 41 00-24	STRAP TORQUE		1
99	532 41 57-42	STANGE		1
116	873 90 05-00	MUTTER		1
125	817 00 05-12	SCHRAUBE		1
143	817 49 05-08	SCHRAUBE		1
153	532 12 47-88	RETAINING RING		1
159	876 02 04-12	SPANNHÜLSE		1
160	532 16 94-84	BOLZEN		1
161	532 10 57-09	FEDER		1
163	532 40 10-34	STANGE		1
166	532 42 83-05	MUTTER		1
167	532 40 52-57	SPERRHAKEN		1
170	532 19 43-22	BEFESTIGUNG		1
171	872 11 06-16	BOLZEN		1
183	532 13 70-57	ABSTANDSSCHLEIBE		1
184	532 40 97-47	KNOPF		1
185	872 11 06-22	BOLZEN		1
186	532 19 43-21	ABSTANDSSCHLEIBE		1
187	819 13 32-10	SCHEIBE		1
188	532 19 43-23	GELENK		1
189	532 19 43-17	PLATTE		1
190	532 19 43-18	RIEMENFÜHRUNG		1
205	532 12 17-48	SCHEIBE		1
210	532 40 09-80	PEDALARM		1
211	532 12 01-83	LAGER		1
214	532 42 12-63	KISSEN		1
215	532 40 17-23	PEDALGUMMI		1
216	532 19 61-31	HALTER		1
221	532 40 31-87	RETAINER SPRING		1
222	879 21 20-10	SCHEIBE		1
225	532 40 33-19	RIEMENFÜHRUNG		1
226	532 40 15-64	HALTER		1
230	532 18 89-67	SCHEIBE		1
263	817 00 06-12	SCHRAUBE		1
268	819 13 16-14	SCHEIBE		1
275	532 18 24-02	PROTECTOR		1

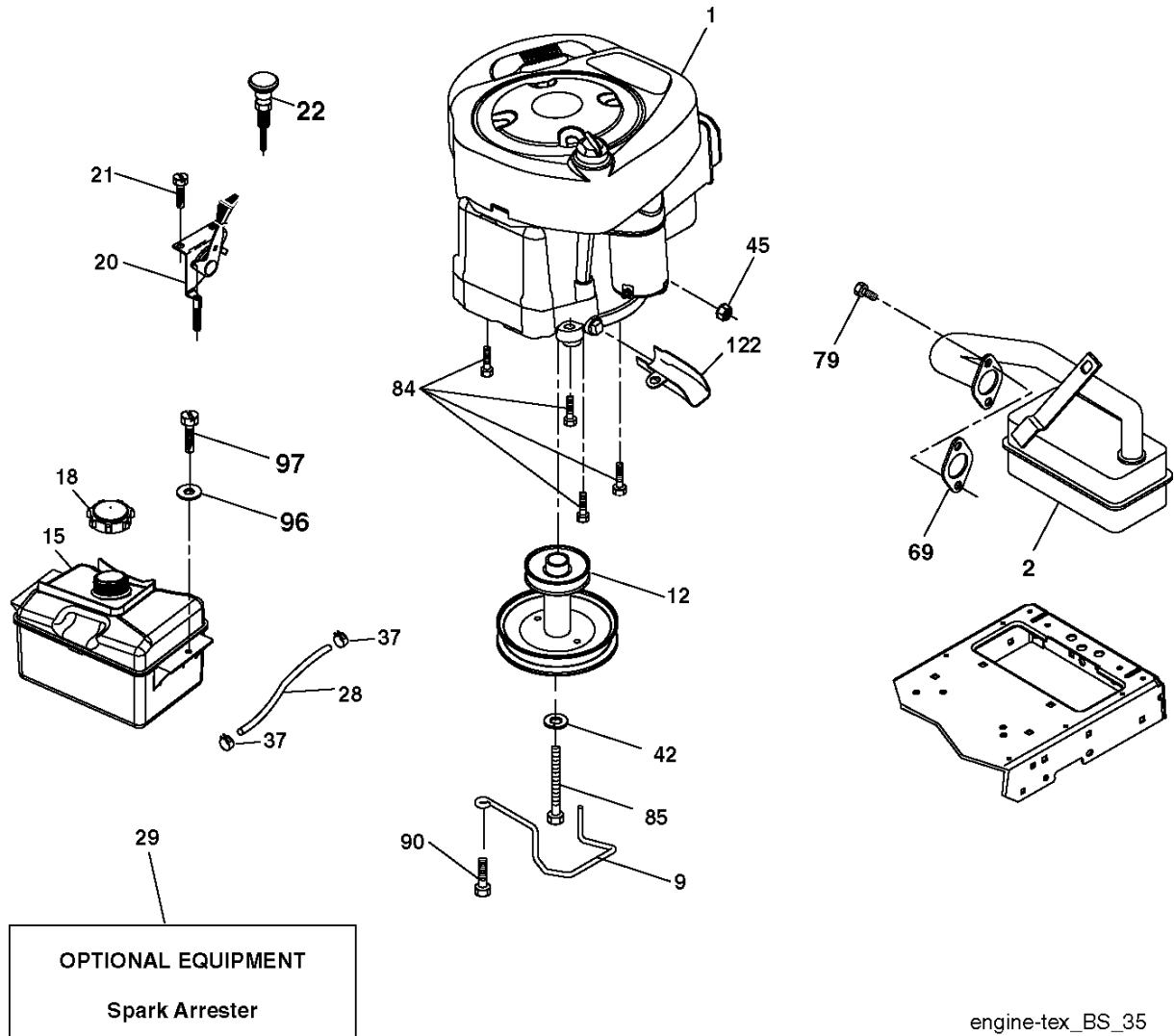

MOTOR

P145107HP, 96041001504, 2010-03

Referenz	Teile Nr	Beschreibung	Bemerkung:	ANZ KIT
1	000 00 00-00	W/O DESCRIPTION	Engine Brigg Model No. 31A507-1391-B1	1
2	532 13 73-52	SCHALLDÄMPFER		1
9	532 19 43-20	RIEMENFÜHRUNG		1
12	532 40 54-71	RIEMENSCHLEIBE		1
15	532 40 75-45	KRAFTSTOFFTANK		1
18	532 42 51-62	DECKEL		1
20	532 41 17-24	BEDIENELEMENT		1
21	532 41 63-58	SCHRAUBE		1
22	532 41 17-25	BEDIENELEMENT		1
28	532 13 70-40	SCHLAUCH		1
29	532 13 71-80	SPARK ARRESTER KIT		1
37	532 12 34-87	SCHLAUCHSCHELLE		1
42	810 04 07-00	SCHEIBE		1
45	873 51 04-00	MUTTER		1
69	532 16 52-91	DICHTUNG		1
79	532 19 23-34	SCHRAUBE		1
84	817 06 06-20	SCHRAUBE		1
85	532 17 39-37	BOLZEN		1
90	817 00 06-16	SCHRAUBE		1
96	819 09 14-16	SCHEIBE		1
97	817 67 04-12	SCHRAUBE		1
122	532 42 19-22	VERLÄNGERUNGSROHR		1

LENKUNG

P145107HP, 96041001504, 2010-03

Referenz	Teile Nr	Beschreibung	Bemerkung:	ANZ KIT
1	532 42 41-46	LENKRAD		1
2	532 41 81-68	ACHSE		1
4	532 40 30-87	SPINDEL		1
5	532 40 30-88	SPINDEL		1
6	532 12 49-31	SCHEIBE		1
7	532 12 17-48	SCHEIBE		1
8	812 00 00-29	SPRENGRING		1
9	532 12 12-32	RADKAPPE		1
13	532 12 17-49	SCHEIBE		1
14	810 04 06-00	SCHEIBE		1
15	873 54 06-00	MUTTER		1
16	532 42 93-73	WELLE		1
19	532 19 47-29	PLATTE		1
20	532 40 97-63	LENKSÄULE		1
21	532 18 67-37	ADAPTER		1
22	532 42 05-37	STÜTZE		1
26	532 42 46-91	EINSATZ		1
28	817 00 06-12	SCHRAUBE		1
33	810 04 05-00	SCHEIBE		1
35	532 19 47-32	PLATTE		1
45	819 11 38-12	SCHEIBE		1
53	532 18 89-67	SCHEIBE		1
57	532 40 74-65	HALTER		1
58	532 19 47-47	BOLZEN		1
59	532 19 47-48	SCHEIBE		1
60	873 97 10-00	MUTTER		1
61	532 19 47-40	GELENK		1
62	532 19 47-41	GELENK		1
63	817 00 05-12	SCHRAUBE		1
64	532 19 98-49	FEDERHALTER		1
66	871 02 07-48	BOLZEN		1
67	532 19 47-37	BUSHING		1
68	873 90 07-00	MUTTER		1
69	532 19 91-62	SCHEIBE		1
70	532 19 61-97	HALTER		1
71	532 19 07-52	WELLE		1
72	532 42 89-82	BOLZEN		1
74	532 12 49-37	BEARING COL. STRG.		1

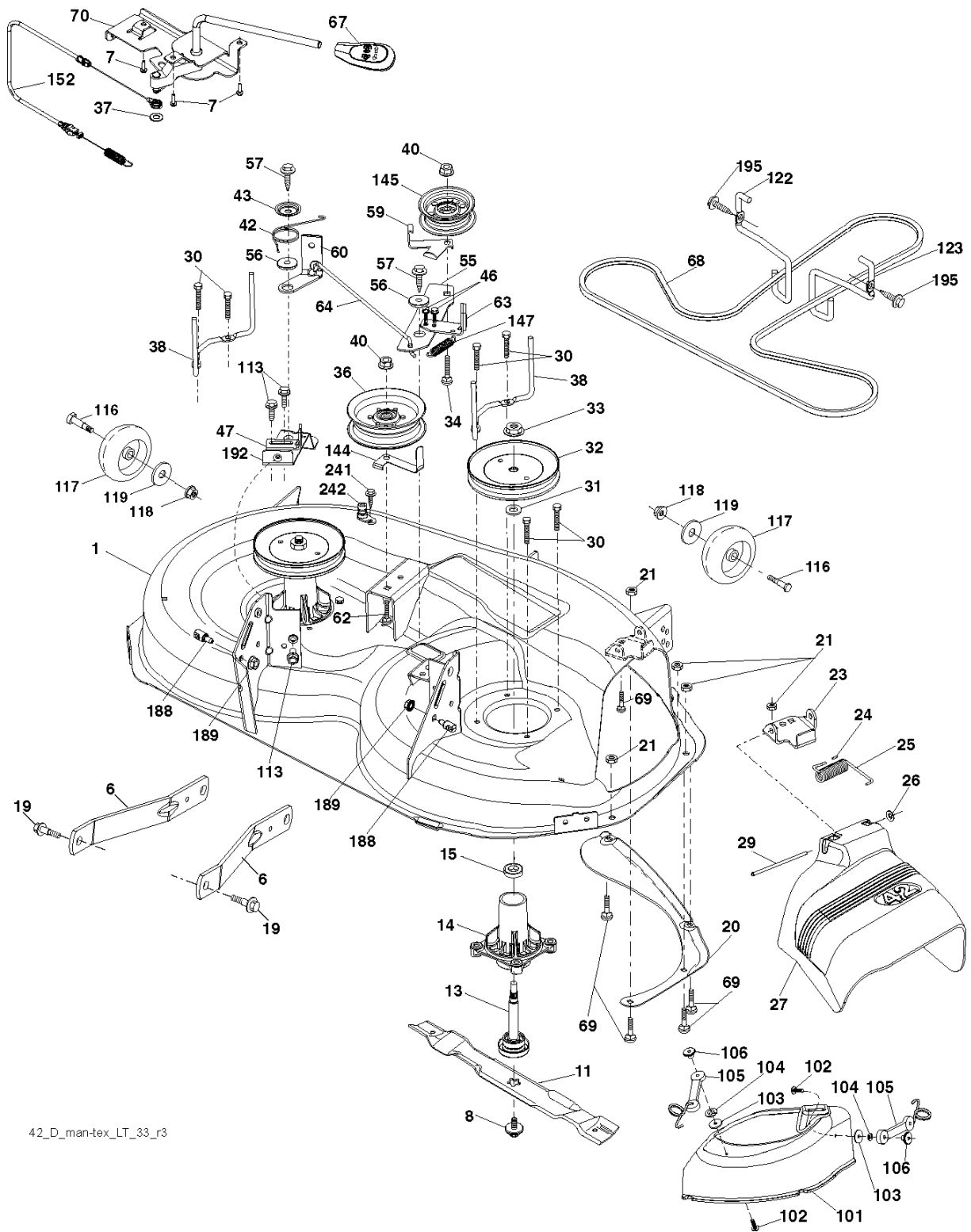

Referenz	Teile Nr	Beschreibung	Bemerkung:	ANZ KIT
1	532 19 64-95	GEHÄUSE		1
6	532 19 51-86	ARM		1
7	532 41 63-58	SCHRAUBE		1
8	532 19 30-03	SCHRAUBE		1
11	532 13 41-49	RIDE ON BLADE		1
13	532 19 28-72	KURBELWELLE		1
14	532 18 72-81	LAGERGEHÄUSE		1
15	532 11 04-85	LAGER		1
19	532 19 65-39	BOLZEN		1
20	532 15 97-70	SCHIENE		1
21	873 68 05-00	MUTTER		1
23	532 19 25-57	SCHARNIER		1
24	532 10 53-04	RADKAPPE		1
25	532 19 70-26	TORSIONSFEDER		1
26	532 11 04-52	MUTTER		1
27	532 40 30-04	SCHIRM		1
29	532 13 14-91	WELLE		1
30	532 17 39-84	SCHRAUBE		1
31	532 18 76-90	SCHEIBE		1
32	532 19 74-73	RIEMENSCHLEIFE		1
33	532 40 02-34	MUTTER		1
34	872 11 06-12	BOLZEN		1
36	532 19 73-79	RIEMENSCHLEIFE		1
37	819 13 13-16	SCHEIBE		1
38	532 19 91-89	RIEMENFÜHRUNG		1
40	873 90 06-00	MUTTER		1
42	532 19 84-10	FEDER		1
43	532 19 72-56	FEDER		1
46	532 13 77-29	SCHRAUBE		1
47	532 19 72-50	HALTER		1
55	532 43 71-10	ARM		1
56	532 19 90-92	ABSTANDSSCHLEIFE		1
57	817 00 06-16	SCHRAUBE		1
59	532 14 10-43	SCHUTZ		1
60	532 19 72-61	ARM		1
62	872 11 06-16	BOLZEN		1
63	532 19 94-77	ARM		1
64	532 19 97-90	GELENK		1
67	532 40 97-92	EINSTELLHEBEL		1
68	532 42 96-36	RIEMEN		1
69	872 14 05-05	BOLZEN		1
70	532 40 12-46	KUPPLUNG		1
101	532 19 31-07	DECKEL		1
102	871 08 10-10	SCHRAUBE		1
103	819 06 12-16	SCHEIBE		1
104	810 07 10-00	SCHEIBE		1
105	532 16 07-93	SPERRHAKEN		1
106	532 12 50-04	MUTTER		1
113	817 00 05-10	BOLZEN		1
116	532 12 48-42	BOLZEN		1
117	532 18 86-06	LAUFRAD		1
118	873 90 06-00	MUTTER		1
119	819 12 14-14	SCHEIBE		1
122	532 19 72-58	RIEMENFÜHRUNG		1
123	532 19 72-59	RIEMENFÜHRUNG		1
144	532 19 92-04	RIEMENFÜHRUNG		1
147	532 40 19-71	FEDER		1
145	532 19 31-97	RIEMENSCHLEIFE		1
152	532 40 87-14	KABEL		1
188	532 19 51-61	GEWINDESTIFT		1
189	873 90 05-00	MUTTER		1
192	532 19 72-60	HALTER		1
195	817 00 06-12	SCHRAUBE		1
241	532 15 29-27	SCHRAUBE		1

Referenz	Teile Nr	Beschreibung	Bemerkung:	ANZ KIT
242	532 41 55-98	PORT.WASHOUT		1
--	532 19 28-70	SPINDEL	(Includes housing, shaft assembly, and bearing only - pulley/nut/washer and blade bolt/washers not included)	1
--	532 43 16-13	SCHNEIDWERK		1

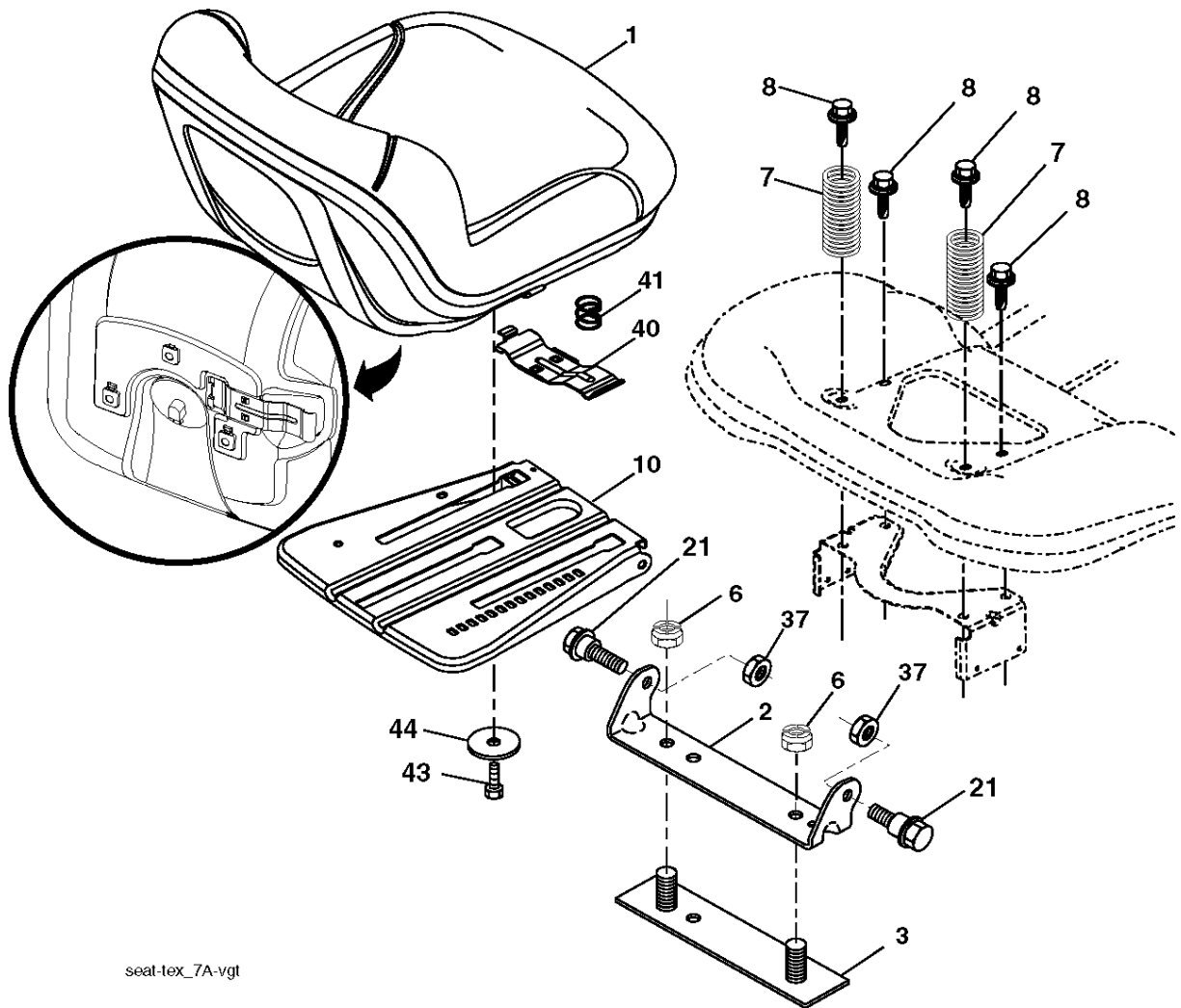

seat-lex_7A-vgt

Referenz	Teile Nr	Beschreibung	Bemerkung:	ANZ KIT
1	532 19 75-11	SITZ		1
2	532 18 01-66	HALTER		1
3	532 14 06-75	SPANNBAND		1
6	873 80 06-00	MUTTER		1
7	532 12 41-81	FEDER		1
8	532 17 18-77	BOLZEN		1
10	532 19 69-77	PLATTE		1
21	532 17 18-52	BOLZEN		1
37	873 80 05-00	LOCK NUT		1
40	532 19 76-61	EINSTELLHEBEL		1
41	532 19 82-00	FEDER		1
43	874 76 06-12	BOLZEN		1
44	819 13 38-12	SCHEIBE		1

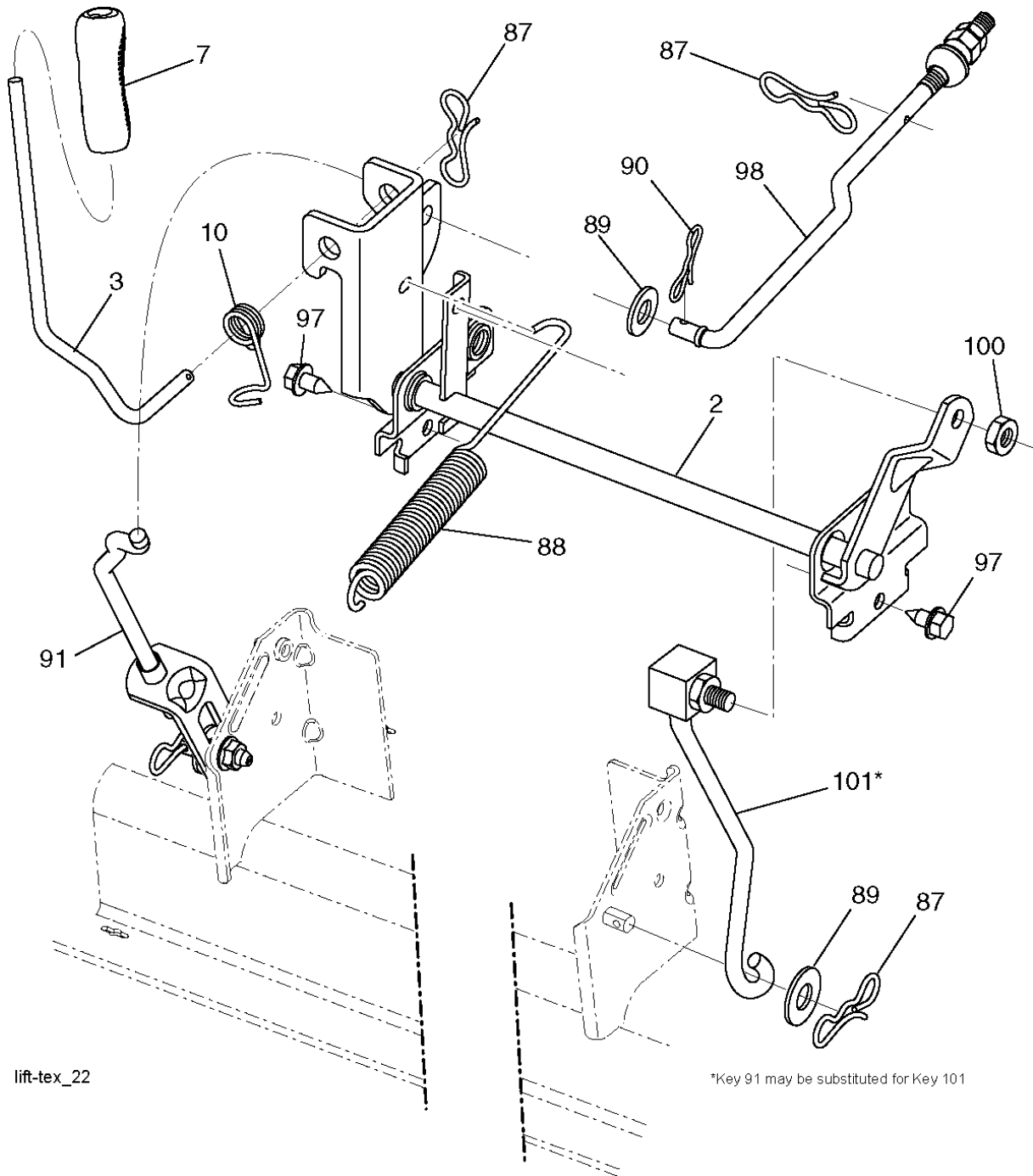

lift-tex_22

*Key 91 may be substituted for Key 101

Referenz	Teile Nr	Beschreibung	Bemerkung:	ANZ KIT
2	532 42 20-26	WELLE		1
3	532 19 52-31	HEBEL		1
7	532 41 17-42	GRIFF		1
10	532 19 63-14	FEDER		1
87	532 19 42-09	FEDER		1
88	532 41 07-10	FEDER		1
89	819 19 19-12	SCHEIBE		1
90	532 19 42-08	BOLZEN		1
91	532 19 51-81	GELENK		1
97	817 00 06-12	SCHRAUBE		1
98	532 19 52-70	GELENK		1
100	873 93 06-00	MÜTTER		1
101	532 40 70-03	GELENK		1