

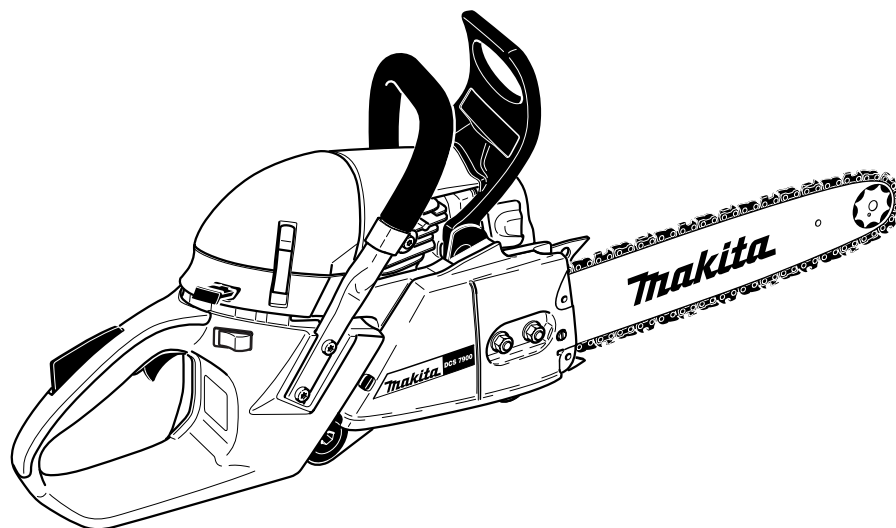

Spare Parts List
Ersatzteilliste
Liste de pièces détachées
Lista de piezas de repuesto

2003-09



DCS6400	DCS6400H
DCS6401	DCS6401H
DCS7300	DCS7300H
DCS7301	DCS7301H
DCS7900	DCS7900H
DCS7901	DCS7901H

995 700 559 (D, GB, F, E)

DCS6400, DCS6401
DCS7300, DCS7301
DCS7900, DCS7901

1

Kraftstofftank, Bügelgriff
Fuel tank, tubular grip
Réserv. carburant, poignée tubulaire
Depósito de combustible, mango tubular

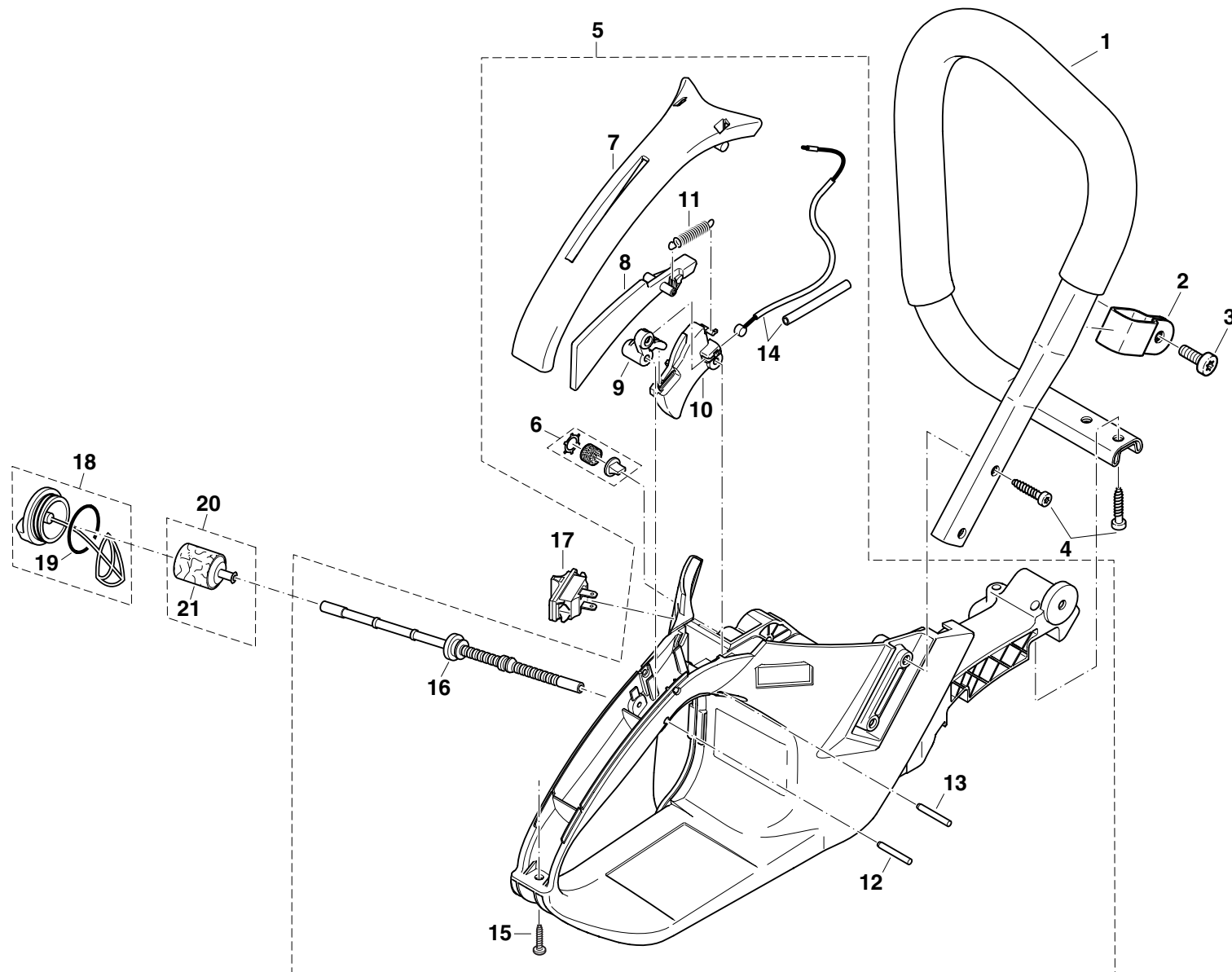

DCS 6400, 6401, 7300, 7301, 7900, 7901



Seite / Page	Pos.	DCS 6400	DCS 6401	DCS 7300	DCS 7301	DCS 7900	DCS 7901	DCS 6400 USA	DCS 6401 USA	DCS 7300 USA	DCS 7301 USA	DCS 7900 USA	DCS 7901 USA	Teil-Nr. Part No. No. de pièce No. de pieza	Hinweise Notes Renseign. Nota	Bezeichnung	Spezifikation Specification	Description	Désignation	Denominación
1	1	1	1	1	1	1	1	1	1	1	1	1	1	038 310 020		BÜGELGRIFF KPL.		TUBULAR HANDLE ASSY.	POIGNÉE TUBULAIRE CPL.	MANGO TUBULAR CPL.
1	2	1	1	1	1	1	1	1	1	1	1	1	1	038 310 060	TI 2002/07	SCHELLE		CLAMP	BRIDE DE FIXATION	ABRAZADERA
1	3	1	1	1	1	1	1	1	1	1	1	1	1	908 006 145		INNENSTERN-SCHRAUBE	6X14	SCREW	VIS	TORNILLO
1	4	4	4	4	4	4	4	4	4	4	4	4	4	913 455 204		INNENSTERN-SCHRAUBE KST.	5,5X20	SCREW	VIS	TORNILLO
1	5	1	1	1	1	1	1	1	1	1	1	1	1	038 114 601		TANK KPL. BLAU		TANK CPL. BLUE	RÉSERVOIR CPL. BLEU	DEPÓSITO CPL. AZUL
1	6	1	1	1	1	1	1	1	1	1	1	1	1	957 114 060		BELÜFTUNGSVENTIL KPL.		AIR VALVE CPL.	SOUPAPE D' AERATION CPL.	VÁLVULA VENTILACION CPL.
1	7	1	1	1	1	1	1	1	1	1	1	1	1	038 114 630		HANDSCHALE BLAU		GRIP PLATE RED BLUE	PLAQUE DE POIGNÉE BLEU	CAPA DE MANGO AZUL
1	8	1	1	1	1	1	1	1	1	1	1	1	1	038 117 020		SICHERHEITSPERRTASTE		CATCH LEVER	LEVIER DE VERROUILLAGE	PALANCA TRINCADA
1	9	1	1	1	1	1	1	1	1	1	1	1	1	038 117 030		UMLENKHEBEL		ROCKER	LEVIER DE RENVOI	PALANCA DE CAMBIO
1	10	1	1	1	1	1	1	1	1	1	1	1	1	038 117 010		GASHEBEL		THROTTLE LEVER	LEVIER D' ACCÉLÉRATION	ACELERADOR
1	11	1	1	1	1	1	1	1	1	1	1	1	1	038 117 050		ZUGFEDER		SPRING	RESSORT	RESORTE
1	12	1	1	1	1	1	1	1	1	1	1	1	1	935 930 240		ZYLINDERSTIFT	3X24	CYLINDRICAL PIN	GOUPILLE CYL.	PRISIONERO
1	13	1	1	1	1	1	1	1	1	1	1	1	1	935 930 280		ZYLINDERSTIFT	3X28	CYLINDRICAL PIN	GOUPILLE CYL.	PRISIONERO
1	14	1	1	1	1	1	1	1	1	1	1	1	1	010 117 040		BOWDENZUG KPL.		BOWDEN CABLE	CÂBLE DE COMMANDE	TRANSMIS. FLEXIBLE BOWDEN
1	15	1	1	1	1	1	1	1	1	1	1	1	1	913 340 204		INNENSTERN-SCHLITZ-SCHRAUBE	4X20 S27	SCREW	VIS	TORNILLO
1	16	1	1	1	1	1	1	1	1	1	1	1	1	038 114 050		KRAFTSTOFFLEITUNG		FUEL LINE	CONDUITE CARB.	TUBO COMB.
1	17	1	1	1	1	1	1	1	1	1	1	1	1	975 001 240		KURZSCHLUßSCHALTER		SHORT-CIRCUIT SWITCH	INTERRUPTEUR COURT-CIRCUIT	INTERRUPTOR CORTO CIRCUITE
1	18	1	1	1	1	1	1	1	1	1	1	1	1	010 114 050		VERSCHLUSSSCHRAUBE KPL		TANK CAP CPL.	BOUCHON RESERVOIR CPL.	TORNILLO DE CIERRE CPL.
1	19	1	1	1	1	1	1	1	1	1	1	1	1	963 228 030		O-RING	28X3	PACKING RING	BAGUE-JOINT	ANILLO DE GUARNICION
1	20	1	1	1	1	1	1	1	1	1	1	1	1	963 601 120		SAUGKOPF KPL.		SUCTION HEAD	TÊTE D'ASPIRATION	CABEZA DE ASPIRACION
1	21	1	1	1	1	1	1	1	1	1	1	1	1	963 601 240		FILZFILTER		FELT FOR SUCTION HEAD	FEUTRE POUR ASPIRATION	FIELTRO DE REPUESTO

DCS6400, DCS6401
DCS7300, DCS7301
DCS7900, DCS7901

2

Abdeckhaube, Luftfilter, Schalldämpfer
Hood, air filter, muffler
Capot protecteur, filtre à air, pot d'échappement
Cubierta protectora, filtro de aire, silencioso

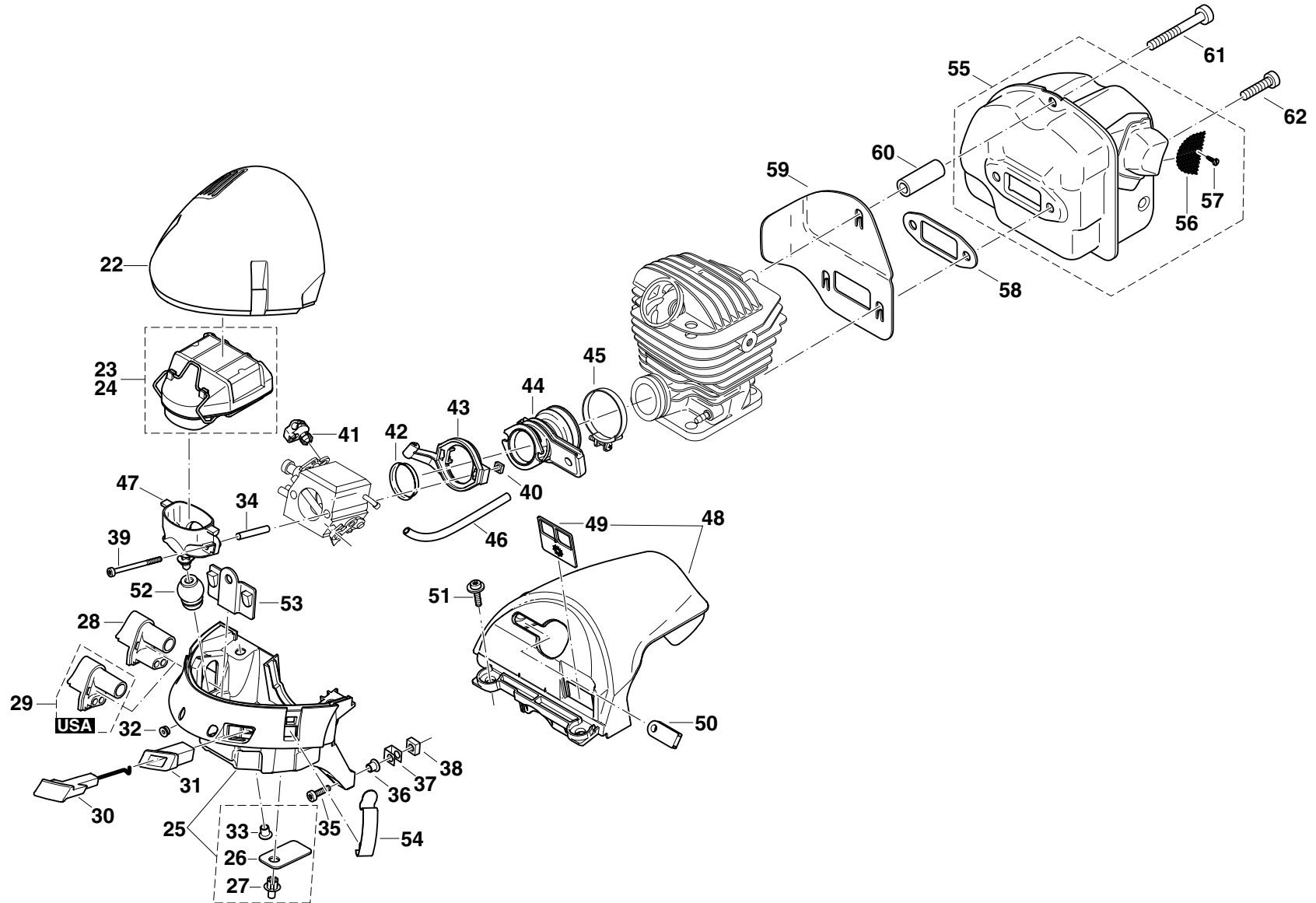

DCS 6400, 6401, 7300, 7301, 7900, 7901



Seite / Page	Pos.	DCS 6400	DCS 6401	DCS 7300	DCS 7301	DCS 7900	DCS 7901	DCS 6400 USA	DCS 6401 USA	DCS 7300 USA	DCS 7301 USA	DCS 7900 USA	DCS 7901 USA	Teil-Nr. Part No. No. de pièce No. de pieza	Hinweise Notes Renseign. Nota	Bezeichnung	Spezifikation Specification	Description	Désignation	Denominación
2	22	1	1	1	1	1	1							038 118 020		DECKEL ROT	RUS	COVER RED	CAPOT ROUGE	CUBIERTA ROJO
2	22	1	1	1	1	1	1	1	1	1	1	1	1	038 118 620		DECKEL GRAU		COVER GREY	CAPOT GRIS	CUBIERTA GRIS
2	23	1	1	1	1	1	1	1	1	1	1	1	1	038 173 101		LUFTFILTER KPL.	VLIES	AIR FILTER CPL.	FILTRE A AIR CPL.	FILTRO DE AIRE CPL.
2	24	1	1	1	1	1	1	1	1	1	1	1	1	038 173 011		LUFTFILTER KPL.	NYLON	AIR FILTER CPL.	FILTRE A AIR CPL.	FILTRO DE AIRE CPL.
2	25	1	1	1	1	1	1	1	1	1	1	1	1	038 118 630		BODEN MIT BUCHSE BLAU		BOTTOM BLUE	FOND BLEU	FONDO AZUL
2	26	2	2	2	2	2	2	2	2	2	2	2	2	038 118 110		GUMMIKLAPPE		RUBBER FLAP	CLAPET CAOUTCHOUC	VALVULA DE GOMA
2	27	2	2	2	2	2	2	2	2	2	2	2	2	938 650 062		SPREIZNIET		RIVET	RIVET	REMACHE
2	28	1	1	1	1	1	1							038 118 080		EINSTELLFUHRUNG		ADJUSTING GUIDE	GUIDAGE D' AJUSTAGE	GUIA DE AJUSTE
2	29							1	1	1	1	1	1	038 118 120		EINSTELLFUHRUNG	USA	ADJUSTING GUIDE	GUIDAGE D' AJUSTAGE	GUIA DE AJUSTE
2	30	1	1	1	1	1	1	1	1	1	1	1	1	038 155 050		CHOKESTANGE		CHOKE SHAFT	LEVIER DE STARTER	PALANCA ESTRANGUL. AIRE
2	31	1	1	1	1	1	1	1	1	1	1	1	1	038 155 020		CHOKEFUHRUNG		CHOKE GUIDE	GAINIE STARTER	GUIA DEL STARTER
2	32	1	1	1	1	1	1	1	1	1	1	1	1	965 401 020		GUMMITULLE		RUBBER BUSH	GAINIE CAOUTCHOUC	BOQUILLA DE CAUCHO
2	33	2	2	2	2	2	2	2	2	2	2	2	2	001 118 100		BUCHSE		BUSHING	DOUILLE	CASQUILLO
2	34	2	2	2	2	2	2	2	2	2	2	2	2	038 155 060		DISTANZROHR	L=30MM	SPACER	DOUILLE DE DISTANCE	CASQUILLO SEPARADOR
2	35	2	2	2	2	2	2	2	2	2	2	2	2	908 005 205		INNENSTERN-SCHRAUBE	5X20	SCREW	VIS	TORNILLO
2	36	2	2	2	2	2	2	2	2	2	2	2	2	001 118 100		BUCHSE		BUSHING	DOUILLE	CASQUILLO
2	37	2	2	2	2	2	2	2	2	2	2	2	2	038 111 050		KLAMMER		CLIP	AGRAFE	GRAPA
2	38	2	2	2	2	2	2	2	2	2	2	2	2	038 111 060		4KT-MUTTER	M5	SQUARE NUT	ECROU CARRÉ	TUERCA CUADR.
2	39	2	2	2	2	2	2	2	2	2	2	2	2	908 204 555		INNENSTERN-SCHRAUBE	4X55	SCREW	VIS	TORNILLO
2	40	2	2	2	2	2	2	2	2	2	2	2	2	921 804 004		4KT-MUTTER	M4	SQUARE NUT	ECROU CARRE	TUERCA CUADR.
2	41	1	1	1	1	1	1	1	1	1	1	1	1	038 155 010		AUFNAHME FÜR BOWDENZUG		RETAINING CLIP	SUPPORT DU DISPOS. DE TIRAGE	TRACCIÓN BOWDEN, SOPORTE
2	42	1	1	1	1	1	1	1	1	1	1	1	1	038 131 030		EINSATZ FÜR ANSAUGSCHLAUCH		INSERT FOR SUCTION HOSE	PIÈCE P. TUYAU D' ASPIRATION	SUPLEMENTO P. TUBO DE ASP.
2	43	1	1	1	1	1	1	1	1	1	1	1	1	038 171 041		FLANSCHRING		FLANGE	BRIDE	BRIDA
2	44	1	1	1	1	1	1	1	1	1	1	1	1	038 131 011		ANSAUGSCHLAUCH		SUCTION HOSE	TUYAU D' ASPIRATION	TUBO DE ASPIRACIÓN
2	45	1	1	1	1	1	1	1	1	1	1	1	1	965 603 050		SCHLAUCHSCHELLE		HOSE CLAMP	COLLIER DE TUYAU	ABRAZADERA
2	46	m	m	m	m	m	m	m	m	m	m	m	m	965 452 380		IMPULSSCHLAUCH	L=65	TUBE	GAINIE	TUBO
2	47	1	1	1	1	1	1	1	1	1	1	1	1	038 171 011		ANSAUGKRÜMMER		CONNECTING MUFF	MANCHON DE JONCTION	MANGUITO DE CON.
2	48	1	1	1	1	1	1	1	1	1	1	1	1	038 118 010		ABDECKHAUBE ROT	RUS	HOOD CPL. RED	CAPOT PROT. CPL. ROUGE	TAPA PROT. CPL. ROJO
2	48	1	1	1	1	1	1	1	1	1	1	1	1	038 118 090		ABDECKHAUBE ROT DEKO	RUS	HOOD CPL. RED	CAPOT PROT. CPL. ROUGE	TAPA PROT. CPL. ROJO
2	48	1	1	1	1	1	1	1	1	1	1	1	1	038 118 610		ABDECKHAUBE GRAU		HOOD CPL. GREY	CAPOT PROT. CPL. GRIS	TAPA PROT. CPL. GRIS
2	48	1	1	1	1	1	1	1	1	1	1	1	1	038 118 690		ABDECKHAUBE GRAU DEKO		HOOD CPL. GREY	CAPOT PROT. CPL. GRIS	TAPA PROT. CPL. GRIS
2	49	1	1	1	1	1	1	1	1	1	1	1	1	038 118 140		WINTERSTOPFEN		INSERT	PIÈCE D' INSERTION	PIEZA DE CIERRE
2	50	1	1	1	1	1	1	1	1	1	1	1	1	038 118 130		KABELDURCHFÜHRUNG		CABLE GUIDE	PASSAGE DU CABLE	BOQUILLA DE PASO PARA CABLES
2	51	2	2	2	2	2	2	2	2	2	2	2	2	917 105 205		INNENSTERN-KOMBISCHRAUBE	M5X20	SCREW	VIS	TORNILLO
2	52	1	1	1	1	1	1	1	1	1	1	1	1	038 171 030		HALTERUNG FÜR ANSAUGKRÜMMER		HOLDER	SUPPORT	SOPORTE
2	53	1	1	1	1	1	1	1	1	1	1	1	1	038 118 100		STOPFEN		PLUG	OBTURATION	TAPABOCADOS
2	54	2	2	2	2	2	2	2	2	2	2	2	2	038 118 071		STAHLKLAMMER		STEELCLIP	AGRAFE	PINZA DE ACERO
2	55	1	1	1	1	1	1	1	1	1	1	1	1	038 174 200		SCHALLDÄMPFER		MUFFLER	POT D' ÉCHAPPEMENT	SILENCIOSO
2	56							1	1	1	1	1	1	038 174 040		FUNKENSCHUTZSIEB KPL.		SPARK ARRESTOR SCREEN CPL.	TAMIS CPL.	TAMIZ CPL.
2	57							1	1	1	1	1	1	915 035 100		ZYLINDERBLECHSCHRAUBE	3,5X10	SCREW	VIS	TORNILLO
2	58	1	1	1	1	1	1	1	1	1	1	1	1	965 531 130		AUSPUFFDICHTUNG		GASKET	JOINT	JUNTA
2	59	1	1	1	1	1	1	1	1	1	1	1	1	038 174 020		ABSCHIRMBLECH		COVER PLATE	TÔLE DE PROTECTION	CHAPA DEFLECTORA
2	60	1	1	1	1	1	1	1	1	1	1	1	1	038 174 030		ZWISCHENSTÜCK		CONNECTING LINK	INTERMEDIAIRE	PIEZA INTERMEDIARIA
2	61	1	1	1	1	1	1	1	1	1	1	1	1	908 305 405		INNENSTERN-SCHRAUBE	M5X40	SCREW	VIS	TORNILLO
2	62	2	2	2	2	2	2	2	2	2	2	2	2	908 405 205		INNENSTERN-SCHRAUBE	5X20	SCREW	VIS	TORNILLO

DCS6400, DCS6401
DCS7300, DCS7301
DCS7900, DCS7901

3

Zylinder, Kurbelgehäuse
Cylinder, crankcase
Cylindre, carter- vilebrequin
Cilindro, carter cigüeñal

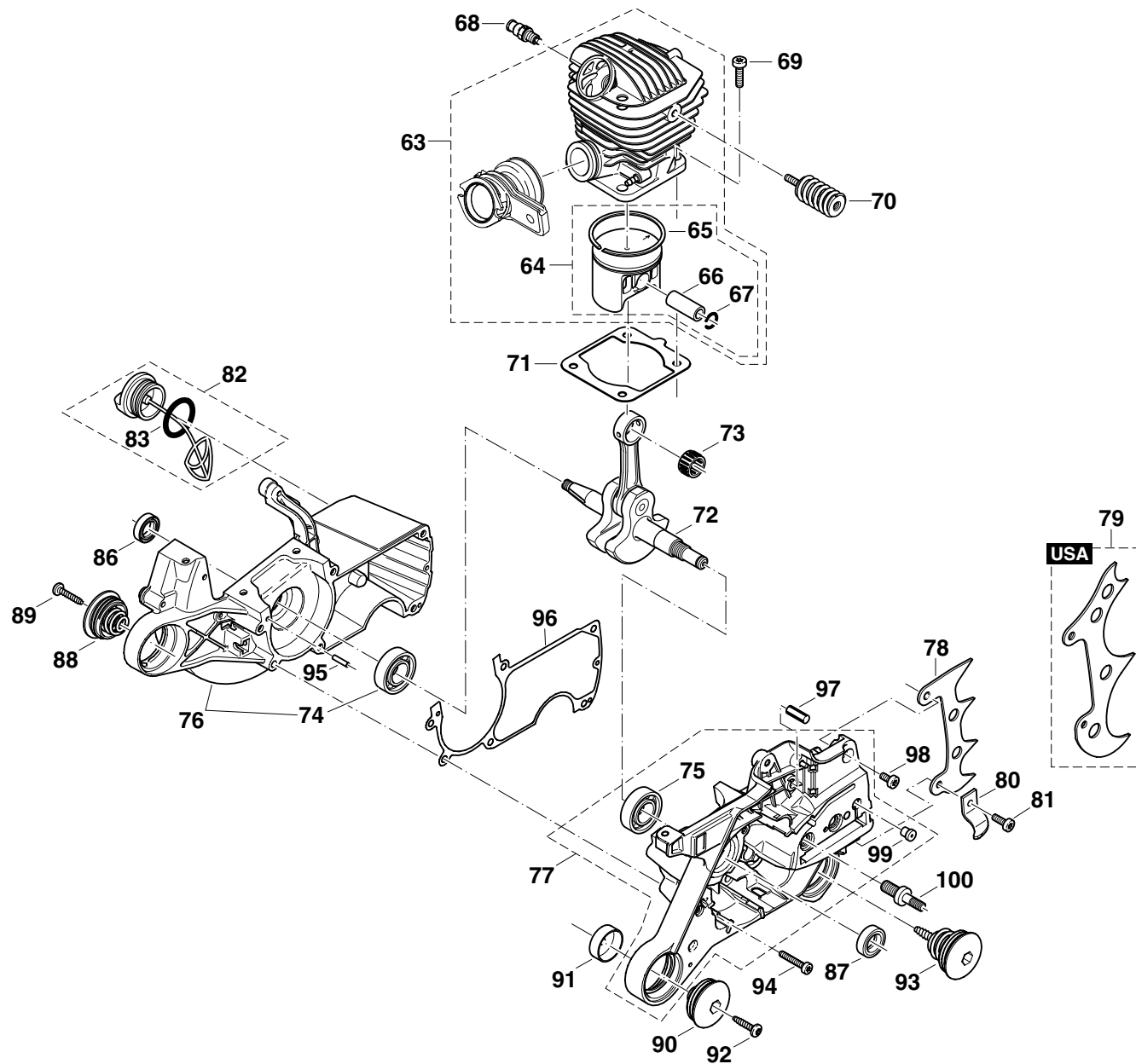

DCS 6400, 6401, 7300, 7301, 7900, 7901



Seite / Page	Pos.	DCS 6400	DCS 6401	DCS 7300	DCS 7301	DCS 7900	DCS 7901	DCS 6400 USA	DCS 6401 USA	DCS 7300 USA	DCS 7301 USA	DCS 7900 USA	DCS 7901 USA	Teil-Nr. Part No. No. de pièce No. de pieza	Hinweise Notes Renseign. Nota	Bezeichnung	Spezifikation Specification	Description	Désignation	Denominación
3	63	1						1						040 130 020	TI 2002/08	ZYLINDER / KOLBEN KPL.	D=47	CYLINDER / PISTON CPL.	CYLINDRE ET PISTON CPL.	CILINDRO CON PISTON CPL.
3	63		1						1					040 130 030	TI 2002/08	ZYLINDER / KOLBEN KPL.	D=47 DECO	CYLINDER / PISTON CPL.	CYLINDRE ET PISTON CPL.	CILINDRO CON PISTON CPL.
3	63			1						1				039 130 020	TI 2002/08	ZYLINDER / KOLBEN KPL.	D=50	CYLINDER / PISTON CPL.	CYLINDRE ET PISTON CPL.	CILINDRO CON PISTON CPL.
3	63				1						1			039 130 030	TI 2002/08	ZYLINDER / KOLBEN KPL.	D=50 DECO	CYLINDER / PISTON CPL.	CYLINDRE ET PISTON CPL.	CILINDRO CON PISTON CPL.
3	63					1						1		038 130 020	TI 2002/08	ZYLINDER / KOLBEN KPL.	D=52	CYLINDER / PISTON CPL.	CYLINDRE ET PISTON CPL.	CILINDRO CON PISTON CPL.
3	63						1						1	038 130 030	TI 2002/08	ZYLINDER / KOLBEN KPL.	D=52 DECO	CYLINDER / PISTON CPL.	CYLINDRE ET PISTON CPL.	CILINDRO CON PISTON CPL.
3	64	1	1					1	1					325 132 031		KOLBEN KPL.	D=47	PISTON CPL.	PISTON CPL.	PISTON CPL.
3	64			1	1					1	1			394 132 111		KOLBEN KPL.	D=50	PISTON CPL.	PISTON CPL.	PISTON CPL.
3	64					1	1					1	1	038 132 000		KOLBEN KPL.	D=52	PISTON CPL.	PISTON CPL.	PISTON CPL.
3	65	1	1					1	1					325 132 050		KOLBENRING	D=47	PISTON RING	SEGMENT DE PISTON	SEGMENTO DE PISTON
3	65			1	1					1	1			394 132 020		KOLBENRING	D=50	PISTON RING	SEGMENT DE PISTON	SEGMENTO DE PISTON
3	65					1	1					1	1	038 132 020		KOLBENRING	D=52	PISTON RING	SEGMENT DE PISTON	SEGMENTO DE PISTON
3	66	1	1	1	1			1	1	1	1			119 132 030		KOLBENBOLZEN		PISTON PIN	AXE DE PISTON	PERNO DE PISTON
3	66					1	1					1	1	038 132 040		KOLBENBOLZEN		PISTON PIN	AXE DE PISTON	PERNO DE PISTON
3	67	2	2	2	2	2	2	2	2	2	2	2	2	119 132 060		SPRENGRING	C12X1	SPRING RING	ANNEAU-RESSORT	ANILLO ELASTICO
3	68		1		1			1		1			1	001 131 150		DEKOMPRESSIONSVENTIL		DECOMPRESSION VALVE	SOUPAPE DE DÉCOMPRESS.	VALVULA DE DECOMPRESIÓN
3	69	4	4	4	4	4	4	4	4	4	4	4	4	908 005 205		INNENSTERN-SCHRAUBE	5X20	SCREW	VIS	TORNILLO
3	70	1	1	1	1	1	1	1	1	1	1	1	1	038 114 151	TI 2002/07	FEDER MIT 2 GEWINDEEINSÄTZEN		SPRING W. THREADED INSERT	RESSORT AVEC FILETAGE	MUELLE CON ROSCA
3	71	1	1	1	1	1	1	1	1	1	1	1	1	965 531 121		ZYLINDERFUßDICHTUNG		GASKET	JOINT	JUNTA
3	72	1	1	1	1	1	1	1	1	1	1	1	1	038 120 020		KURBELWELLE KPL.		CRANKSHAFT CPL.	VILEBREQUIN CPL.	CIGUENAL CPL.
3	73	1	1	1	1	1	1	1	1	1	1	1	1	962 210 019		NADELKAFIG		NEEDLE CAGE	CAGE A AIGUILLES	JAULA DE AGUJAS
3	74	1	1	1	1	1	1	1	1	1	1	1	1	960 102 159		KUGELLAGER	6202	BALL BEARING	ROULEMENT	RODAMIENTO
3	75	1	1	1	1	1	1	1	1	1	1	1	1	960 102 179		KUGELLAGER	6203 C4	BALL BEARING	ROULEMENT	RODAMIENTO
3	76	1	1	1	1	1	1	1	1	1	1	1	1	038 111 630		KURBELGEHAUSE MS BLAU		CRANKC. MAG. SIDE BLUE	CARTER-COTÉ MAGN. BLEU	CÁRTER CIG. LADO MAG. AZUL
3	77	1	1	1	1	1	1	1	1	1	1	1	1	038 111 641		KURBELGEHAUSE KS BLAU		CRANKC. CLUTCH SIDE BLUE	CARTER-COTÉ EMBR. BLEU	CÁRTER CIG. LADO EMBR. AZUL
3	78	1	1	1	1	1	1							038 250 020		ZACKENLEISTE		SPIKE BAR	BARRE DENTÉE	BARRA DENTADA
3	79							1	1	1	1	1	1	038 250 200		ZACKENLEISTE	USA	SPIKE BAR	BARRE DENTÉE	BARRA DENTADA
3	80	1	1	1	1	1	1	1	1	1	1	1	1	038 111 080		KETTENFÄNGER		CHAIN CATCH	ARRÊTE-CHAÎNE	BULÓN DE RETENCIÓN
3	81	1	1	1	1	1	1	1	1	1	1	1	1	908 005 165		INNENSTERN-SCHRAUBE	5x16	SCREW	VIS	TORNILLO
3	82	1	1	1	1	1	1	1	1	1	1	1	1	010 114 050		VERSCHLUSSSCHRAUBE KPL		TANK CAP CPL.	BOUCHON RESERVOIR CPL.	TORNILLO DE CIERRE CPL.
3	83	1	1	1	1	1	1	1	1	1	1	1	1	963 228 030		O-RING	28X3	PACKING RING	BAGUE-JOINT	ANILLO DE GUARNICION
3	86	1	1	1	1	1	1	1	1	1	1	1	1	962 900 052		RADIALDICHTRING	15/24/7	RADIAL RING	JOINT RADIAL	ANILLO RADIAL
3	87	1	1	1	1	1	1	1	1	1	1	1	1	962 900 061		RADIALDICHTRING	17X28X5/4	RADIAL RING	JOINT RADIAL	ANILLO RADIAL
3	88	1	1	1	1	1	1	1	1	1	1	1	1	038 114 130		FEDER KPL. MIT KAPPE		SPRING CPL. WITH CAP	RESSORT CPL.	RESORTE CPL.
3	89	1	1	1	1	1	1	1	1	1	1	1	1	913 455 204		INNENSTERN-SCHRAUBE KST.	5,5X20	SCREW	VIS	TORNILLO
3	90	1	1	1	1	1	1	1	1	1	1	1	1	038 114 130		FEDER KPL. MIT KAPPE		SPRING CPL. WITH CAP	RESSORT CPL.	RESORTE CPL.
3	91	1	1	1	1	1	1	1	1	1	1	1	1	038 114 190		TOPF		POT	CAPUCHON	POTE
3	92	1	1	1	1	1	1	1	1	1	1	1	1	913 455 204		INNENSTERN-SCHRAUBE KST.	5,5X20	SCREW	VIS	TORNILLO
3	93	1	1	1	1	1	1	1	1	1	1	1	1	038 114 140		FEDER KPL. MIT KAPPE		SPRING CPL. WITH CAP	RESSORT CPL.	RESORTE CPL.
3	94	6	6	6	6	6	6	6	6	6	6	6	6	908 005 305		INNENSTERN-SCHRAUBE	5X30	SCREW	VIS	TORNILLO
3	95	2	2	2	2	2	2	2	2	2	2	2	2	936 430 160		SPIRALSPANNSTIFT	3X16	SPIRAL CLAMPING PIN	GOUPILLE A SPIRALE DE TEN	PASADOR
3	96	1	1	1	1	1	1	1	1	1	1	1	1	038 111 042		KURBELGEHAUSEDICHTUNG		GASKET	JOINT	JUNTA
3	97	1	1	1	1	1	1	1	1	1	1	1	1	934 660 250		KERBSTIFT	6x24	SLOTTED PIN	GOUPILLE FENDUE	CLAVIJA MUESCA
3	98	1	1	1	1	1	1	1	1	1	1	1	1	908 005 125		INNENSTERN-SCHRAUBE	5X12	SCREW	VIS	TORNILLO
3	99	1	1	1	1	1	1	1	1	1	1	1	1	010 245 030		BELÜFTUNGSVENTIL		VENT VALVE	SOUPAPE D' AÉRATION	VALVULA VENTILACIÓN
3	100	2	2	2	2	2	2	2	2	2	2	2	2	038 232 010		BEFESTIGUNGSBOLZEN		BOLT	BOULON	BULÓN

DCS6400, DCS6401
DCS7300, DCS7301
DCS7900, DCS7901

4

Zündelektronik, Anwerfvorrichtung
Ignition electronics, starter
Allumage électronique, dispositif de démarrage
Bobina encendido, dispositivo de arranque

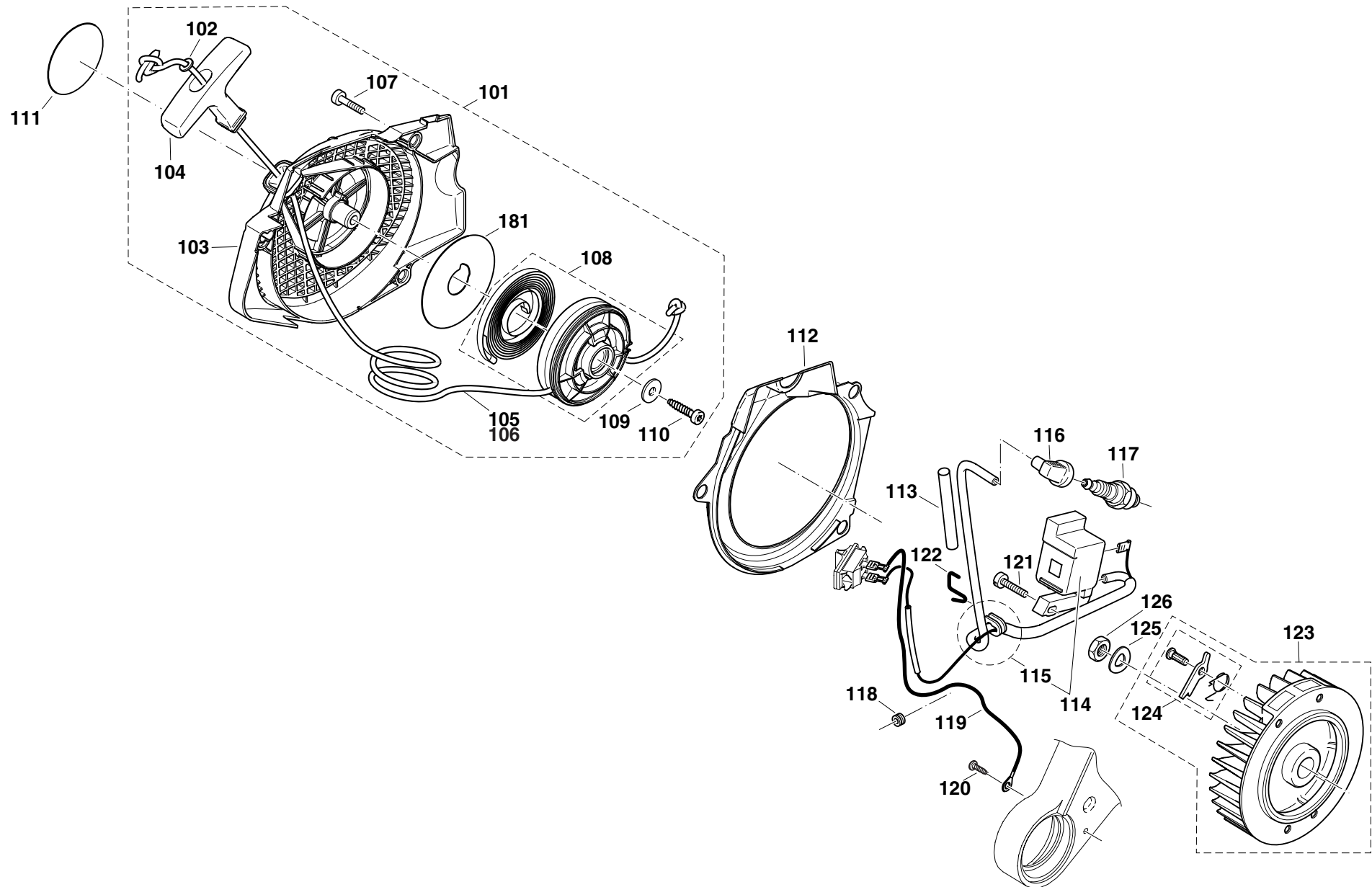

DCS 6400, 6401, 7300, 7301, 7900, 7901



Seite / Page	Pos.	DCS 6400	DCS 6401	DCS 7300	DCS 7301	DCS 7900	DCS 7901	DCS 6400 USA	DCS 6401 USA	DCS 7300 USA	DCS 7301 USA	DCS 7900 USA	DCS 7901 USA	Teil-Nr. Part No. No. de pièce No. de pieza	Hinweise Notes Renseign. Nota	Bezeichnung	Spezifikation Specification	Description	Désignation	Denominación
4	101	1	1	1	1	1	1	1	1	1	1	1	1	038 160 601		ANWERFVORRICHTUNG KPL. BLAU		STARTER ASSY. BLUE	DISPOS. DE DÉMARRAGE CPL. BLEU	DISPOS. DE ARRANQUE CPL. AZUL
4	102	1	1	1	1	1	1	1	1	1	1	1	1	928 405 000		SPANNSCHEIBE		SPRING WASHER	RONDELLE ELASTIQUE	ARANDELA ELÁSTICA
4	103	1	1	1	1	1	1	1	1	1	1	1	1	038 112 630		VENTILATORGEHÄUSE BLAU		FAN HOUSING BLUE	CARTER DE VENTILATEUR BLEU	CÁRTER DE VENTILADOR AZUL
4	104	1	1	1	1	1	1	1	1	1	1	1	1	001 161 010		ANWERFGRIF		STARTER GRIP	POIGNÉE DE LANCEMENT	TIRADOR DE ARRANQUE
4	105	1	1	1	1	1	1	1	1	1	1	1	1	108 164 020		ANWERFSEIL	D=3,5 L=980MM	STARTER ROPE	CÂBLE DE DÉMARRAGE	CORDÓN DE ARRANQUE
4	106	1	1	1	1	1	1	1	1	1	1	1	1	985 000 155	ACC.	ANWERFSEIL	D=3,5 L=100M	STARTER ROPE	CÂBLE DE DÉMARRAGE	CORDÓN DE ARRANQUE
4	107	3	3	3	3	3	3	3	3	3	3	3	3	908 605 205		INNENSTERN-SCHRAUBE	M5X20	SCREW	VIS	TORNILLO
4	108	1	1	1	1	1	1	1	1	1	1	1	1	038 162 022		SEILTROMMEL KPL. MIT RÜCKHOLFEDER		CABLE DRUM CPL.	TAMBOUR DE CÂBLE CPL.	TAMBOUR PARA CORDÓN CPL.
4	109	1	1	1	1	1	1	1	1	1	1	1	1	924 605 510		SCHEIBE	5,5X18X1,6	WASHER	RONDELLE	ARANDELA
4	110	1	1	1	1	1	1	1	1	1	1	1	1	913 455 204		INNENSTERN-SCHRAUBE KST.	5,5X20 KST.	SCREW	VIS	TORNILLO
4	111	1						1						980 114 789		SCHILD	DCS 6400	LABEL	PLAQUE	CALCOMANIA
4	111		1						1					980 114 835		SCHILD	DCS 6401	LABEL	PLAQUE	CALCOMANIA
4	111			1						1				980 114 788		SCHILD	DCS 7300	LABEL	PLAQUE	CALCOMANIA
4	111				1						1			980 114 836		SCHILD	DCS 7301	LABEL	PLAQUE	CALCOMANIA
4	111					1						1		980 114 787		SCHILD	DCS 7900	LABEL	PLAQUE	CALCOMANIA
4	111						1						1	980 114 837		SCHILD	DCS 7901	LABEL	PLAQUE	CALCOMANIA
4	112	1	1	1	1	1	1	1	1	1	1	1	1	038 112 020		LUFTFÜHRUNG		AIR DUCT	PLAQUE DE VENTILATION	PLACA VENTILACIÓN
4	113	m	m	m	m	m	m	m	m	m	m	m	m	970 502 110		ISOLIERSCHLAUCH	A6X0,5 L=140	INSULATING HOSE	TUYAU ISOLANT	MANGO AISLANTE
4	114	1	1	1	1	1	1	1	1	1	1	1	1	038 143 020		ZÜNDSPULE KPL. SCHWARZ		IGNITION COIL BLACK	BOBINE D' ALLUMAGE NOIR	BOBINA ENCENDIDO NEGRO
4	115	1	1	1	1	1	1	1	1	1	1	1	1	038 143 030		KABELBAUM		CABLE HARNESS	FAISCEAU DE CÂBLES	MAZO DE CABLES
4	116	1	1	1	1	1	1	1	1	1	1	1	1	957 604 240		ZÜNDKERZENSTECKER		PLUG CAP	FICHE DE BOUGIE	TAPA DE BUJIA
4	117	1	1	1	1	1	1	1	1	1	1	1	1	965 603 021		ZÜNDKERZE		SPARK PLUG	BOUGIE	BUJIA
4	118	1	1	1	1	1	1	1	1	1	1	1	1	965 401 011		GUMMITÜLLE		RUBBER BUSH	GAINÉ CAOUTCHOUC	BOQUILLA DE CAUCHO
4	119	1	1	1	1	1	1	1	1	1	1	1	1	970 311 540		MASSELEITUNG		EARTH CABLE	FIL DE MASSE	CONDUCCIÓN A MASA
4	120	1	1	1	1	1	1	1	1	1	1	1	1	915 135 100		ZYLINDERBLECHSCHRAUBE	BZ3,5X9,5	SCREW	VIS	TORNILLO
4	121	2	2	2	2	2	2	2	2	2	2	2	2	908 304 205		INNENSTERN-SCHRAUBE	4X10X20 S27	SCREW	VIS	TORNILLO
4	122	2	2	2	2	2	2	2	2	2	2	2	2	038 111 110		KLAMMER		CLIP	AGRAFE	GRAPA
4	123	1	1	1	1	1	1	1	1	1	1	1	1	038 141 000		POLRAD KPL.		FLYWHEEL ASSY.	ROUE POLAIRE CPL.	VOLANTE ENCENDIDO
4	124	2	2	2	2	2	2	2	2	2	2	2	2	108 166 051		ANWERFKLINKE KPL.		STARTER RATCHET CPL.	CLIQUET CPL.	TRINQUETE ARRANQUE CPL.
4	125	1	1	1	1	1	1	1	1	1	1	1	1	926 208 001		FEDERSCHEIBE	B8	SPRING WASHER	RONDELLE A RESSORT	ARANDELA ELASTICO
4	126	1	1	1	1	1	1	1	1	1	1	1	1	920 208 024		6KT-MUTTER	M8X1	HEXAGONAL NUT	ECROU HEXAGONAL	TUERCA HEXAGONAL
4	181	1	1	1	1	1	1	1	1	1	1	1	1	038 162 050		AUSGLEICHSCHEIBE		SPACER	RONDELLE	ARANDELA

DCS6400, DCS6401
DCS7300, DCS7301
DCS7900, DCS7901

5

Ölpumpe, Kupplung
Oil pump, clutch
Pompe à huile, embrayage
Bomba de aceite, embrague

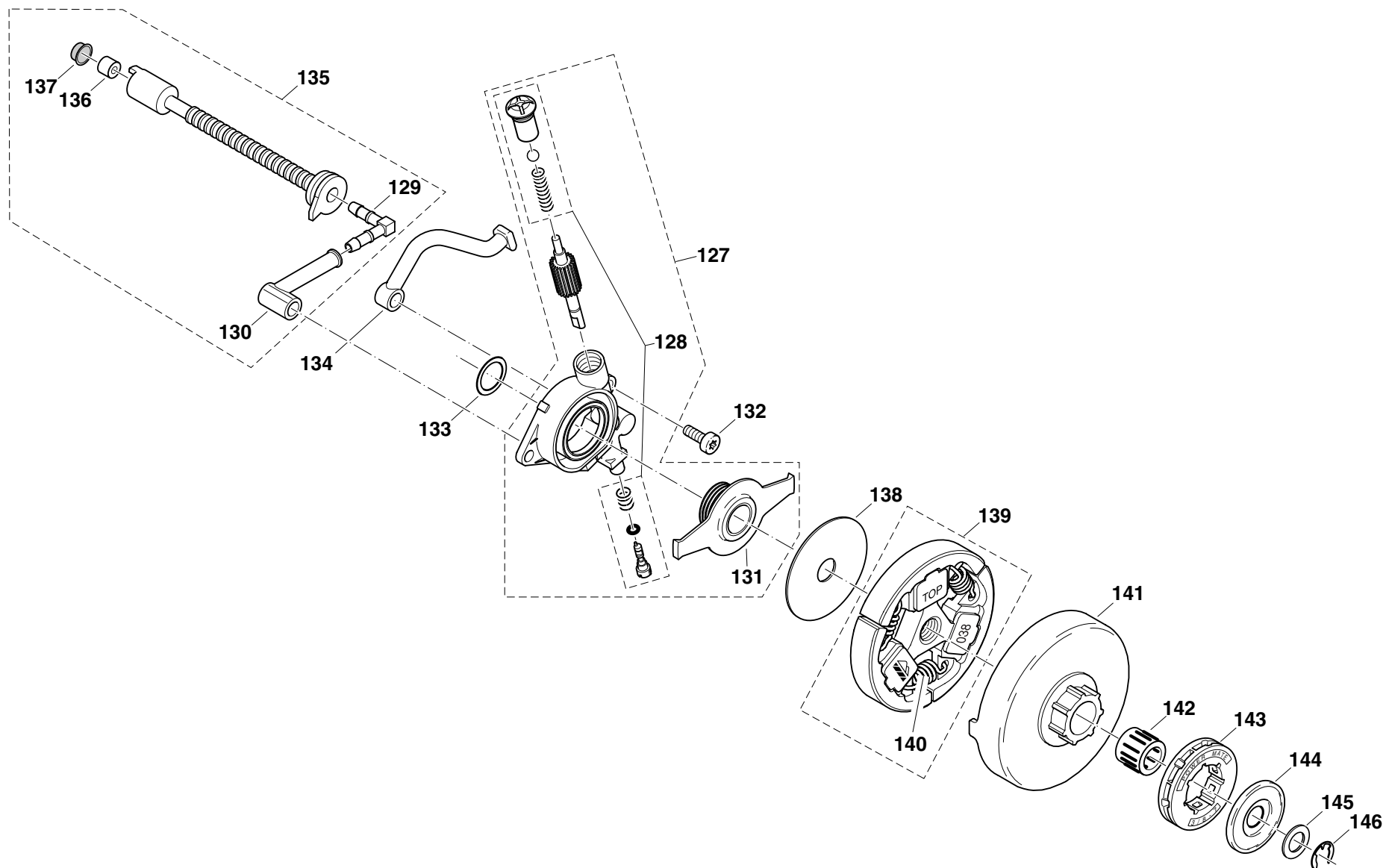

DCS 6400, 6401, 7300, 7301, 7900, 7901



Seite / Page	Pos.	DCS 6400	DCS 6401	DCS 7300	DCS 7301	DCS 7900	DCS 7901	DCS 6400 USA	DCS 6401 USA	DCS 7300 USA	DCS 7301 USA	DCS 7900 USA	DCS 7901 USA	Teil-Nr. Part No. No. de pièce No. de pieza	Hinweise Notes Renseign. Nota	Bezeichnung	Spezifikation Specification	Description	Désignation	Denominación
5	127	1	1	1	1	1	1	1	1	1	1	1	1	038 245 010		ÖLPUMPE KPL.		OIL PUMP CPL.	POMPE À HUILE CPL.	BOMBA DE ACEITE CPL.
5	128	1	1	1	1	1	1	1	1	1	1	1	1	030 245 070		REPARATURSATZ		REPAIR KIT	JEU DE RÉPARATION	JUEGO DE REPARAR
5	129	1	1	1	1	1	1	1	1	1	1	1	1	001 245 140		WINKELNIPPEL		ANGULAR NIPPLE	TÉTON COUDÉ	BOUQUILLA DE TUBO
5	130	1	1	1	1	1	1	1	1	1	1	1	1	038 245 110		ÖLLEITUNG		OIL LINE	CONDUITE HUILE	TUBO ACEITE
5	131	1	1	1	1	1	1	1	1	1	1	1	1	038 245 030		PUMPENANTRIEB		PUMP DRIVE	LE COMMANDE DE POMPE	PROPULSOR DE LA BOMBA
5	132	2	2	2	2	2	2	2	2	2	2	2	2	908 005 125		INNENSTERN-SCHRAUBE	5X12	SCREW	VIS	TORNILLO
5	133	1	1	1	1	1	1	1	1	1	1	1	1	038 224 020		ANLAUFSCHLEIBE		DISC	DISQUE	ARANDELA
5	134	1	1	1	1	1	1	1	1	1	1	1	1	038 245 060		ÖLDRUCKLEITUNG		OIL LINE	CONDUITE HUILE	TUBO ACEITE
5	135	1	1	1	1	1	1	1	1	1	1	1	1	038 245 020		ÖLSAUGLEITUNG KPL.		SUCTION LINE OIL CPL.	CONDUITE D'ASPIR. HUILE CPL.	CONDUCTO DE ASPIR. ACEITE CPL.
5	136	1	1	1	1	1	1	1	1	1	1	1	1	900 005 066		DISTANZRING		DISTANCE RING	BAGUE DE DISTANCE	ANILLO SEPERADOR
5	137	1	1	1	1	1	1	1	1	1	1	1	1	963 601 100		SIEB		STRAINER SCREEN	TAMIS	TAMIZ
5	138	1	1	1	1	1	1	1	1	1	1	1	1	001 182 041		FÜHRUNGSSCHLEIBE		GUIDE DISC	DISQUE DE GUIDAGE	ARANDELA
5	139	1	1	1	1	1	1	1	1	1	1	1	1	038 180 010		KUPPLUNG KPL.		CLUTCH ASSY.	EMBRAYAGE CPL.	EMBRAGUE CPL.
5	140	3	3	3	3	3	3	3	3	3	3	3	3	024 184 021		ZUGFEDER		SPRING	RESSORT	RESORTE
5	141	1	1	1	1	1	1	1	1	1	1	1	1	038 223 020		KUPPLUNGSTROMMEL		CLUTCH DRUM	TAMBOUR	TAMBOR
5	142	1	1	1	1	1	1	1	1	1	1	1	1	962 210 024		NADELKÄFIG	10X16X12	NEEDLE CAGE	CAGE À AIGUILLES	JAULA DE AGUJAS
5	143	1	1	1	1	1	1	1	1	1	1	1	1	119 224 070		ZAHNKRANZ	T=3/8", Z=7	RIM SPROCKET	PIGNON A GAGUE	CORONA PINON
5	144	1	1	1	1	1	1	1	1	1	1	1	1	001 224 011		TOPFSCHLEIBE		DISC	DISQUE	ARANDELA
5	145	1	1	1	1	1	1	1	1	1	1	1	1	021 224 010		ANLAUFSCHLEIBE		DISC	DISQUE	ARANDELA
5	146	1	1	1	1	1	1	1	1	1	1	1	1	927 408 000		SICHERUNGSSCHLEIBE	D=8X1,3	WASHER	RONDELLE	ARANDELA

DCS6400, DCS6401
DCS7300, DCS7301
DCS7900, DCS7901

6

Kettenbremse
Chain brake
Frein de chaîne
Freno de cadena

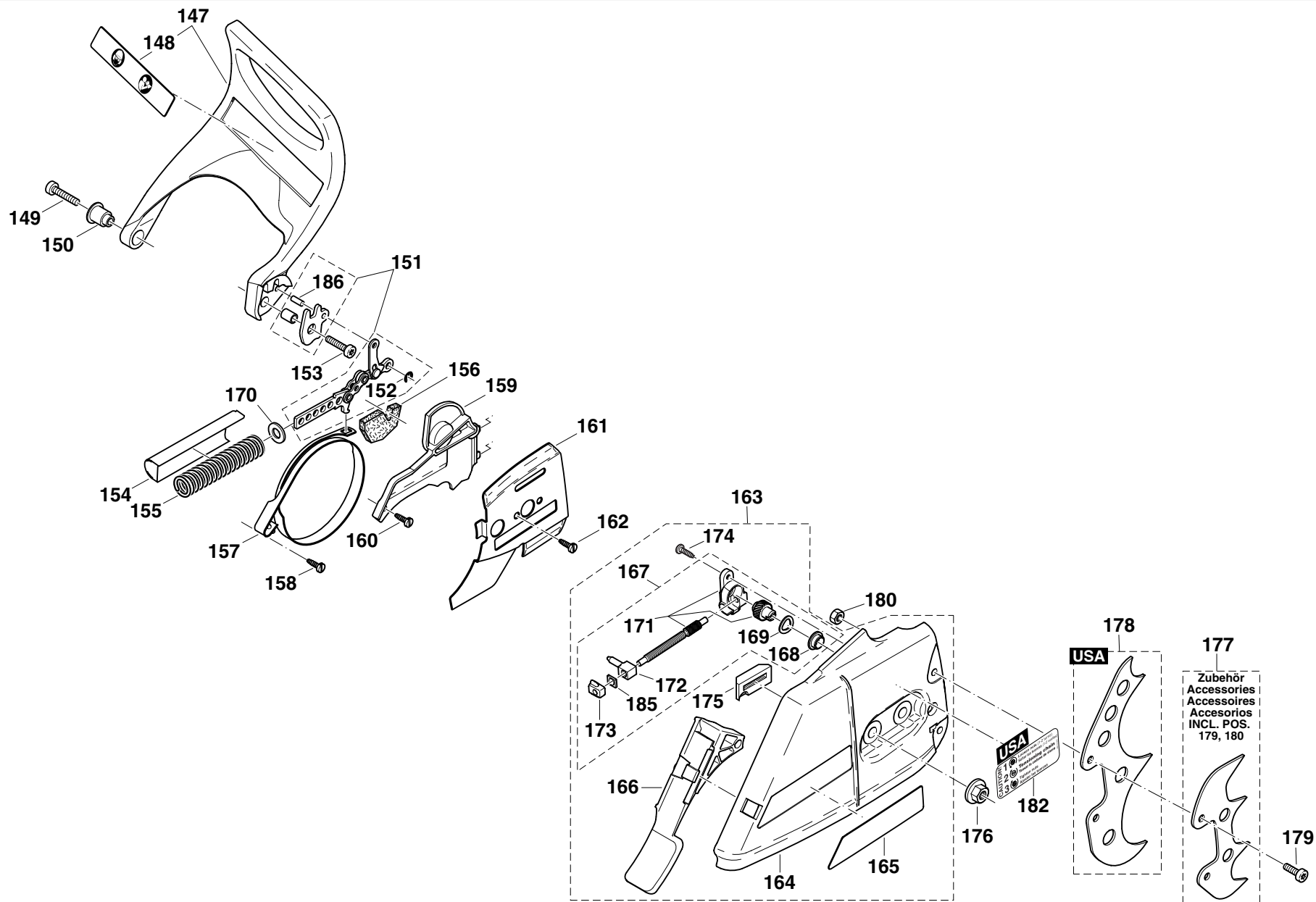

DCS 6400, 6401, 7300, 7301, 7900, 7901



Seite / Page	Pos.	DCS 6400	DCS 6401	DCS 7300	DCS 7301	DCS 7900	DCS 7901	DCS 6400 USA	DCS 6401 USA	DCS 7300 USA	DCS 7301 USA	DCS 7900 USA	DCS 7901 USA	Teil-Nr. Part No. No. de pièce No. de pieza	Hinweise Notes Renseign. Nota	Bezeichnung	Spezifikation Specification	Description	Désignation	Denominación
6	147	1	1	1	1	1	1	1	1	1	1	1	1	038 213 220		HANDSCHUTZ KPL.		HAND GUARD CPL.	PROTÈGE-MAIN CPL.	PROTECTOR DE MANO CPL.
6	148	1	1	1	1	1	1	1	1	1	1	1	1	980 114 237		HINWEISSCHILD HANDSCH.		LABEL	PLAQUE	CALCOMANIA
6	149	1	1	1	1	1	1	1	1	1	1	1	1	908 405 205		INNENSTERN-SCHRAUBE	5X20	SCREW	VIS	TORNILLO
6	150	1	1	1	1	1	1	1	1	1	1	1	1	038 213 160		BUCHSE		BUSHING	DOUILLE	CASQUILLO
6	151	1	1	1	1	1	1	1	1	1	1	1	1	957 213 030		AUSRÜCKMECHANISMUS KPL.		BRAKING MECHANISM	MÉCANISME DE FREINAGE	MECANISMO DE FRENO
6	152	1	1	1	1	1	1	1	1	1	1	1	1	927 304 000		SICHERUNGSSCHEIBE	4	WASHER	RONDELLE	ARANDELA
6	153	1	1	1	1	1	1	1	1	1	1	1	1	908 005 206		ZYLINDERSCHRAUBE	5X20	SCREW	VIS	TORNILLO
6	154	1	1	1	1	1	1	1	1	1	1	1	1	038 213 150		FEDERTOPF		POT	CAPUCHON	POTE
6	155	1	1	1	1	1	1	1	1	1	1	1	1	038 213 130		DRUCKFEDER		SPRING	RESSORT	RESORTE
6	156	1	1	1	1	1	1	1	1	1	1	1	1	038 213 200		SCHAUMSTOFFPLATTE		FOAM SPONGE	PLAQUE DE MOUSSE DE NYLON	CHAPA DE ESPUMA DE PLÁST.
6	157	1	1	1	1	1	1	1	1	1	1	1	1	038 213 010		BREMSBAND		BRAKE SPRING	RESSORT DE FREIN	CINTA DE FRENO
6	158	1	1	1	1	1	1	1	1	1	1	1	1	915 135 100		ZYLINDERBLECHSCHRAUBE	BZ3,5X9,5	SCREW	VIS	TORNILLO
6	159	1	1	1	1	1	1	1	1	1	1	1	1	038 213 040		ABDECKPLATTE		PLATE	PLAQUE	PLANCHA
6	160	1	1	1	1	1	1	1	1	1	1	1	1	915 135 100		ZYLINDERBLECHSCHRAUBE	BZ3,5X9,5	SCREW	VIS	TORNILLO
6	161	1	1	1	1	1	1	1	1	1	1	1	1	038 111 030		KETTENFÜHRUNGSBLECH		GUIDE PLATE	TÔLE DE GUIDAGE	CHAPA DE GUÍA
6	162	1	1	1	1	1	1	1	1	1	1	1	1	915 135 100		ZYLINDERBLECHSCHRAUBE	BZ3,5X9,5	SCREW	VIS	TORNILLO
6	163	1	1	1	1	1	1	1	1	1	1	1	1	038 213 601		KETTENRADSCHUTZ KPL. BLAU		SPROCKET GUARD CPL. BLUE	PROTÈGE-PIGNON CPL. BLEU	PROTECTOR DE PIÑON CPL. AZUL
6	164	1	1	1	1	1	1	1	1	1	1	1	1	038 213 635		KETTENRADSCHUTZ BLAU		SPROCKET GUARD BLUE	PROTÈGE-PIGNON BLEU	PROTECTOR DE PIÑON AZUL
6	165	1	1	1	1	1	1	1	1	1	1	1	1	980 114 784		SCHILD	MAKITA	LABEL	PLAQUE	CALCOMANIA
6	166	1	1	1	1	1	1	1	1	1	1	1	1	038 213 190		SPANABWEISER		CHIP GUIDE	GUIDE DE COPEAUX	SALIDA DE VIRUTAS
6	167	1	1	1	1	1	1	1	1	1	1	1	1	957 213 021		KETTENSANNANTRIEB KPL.		CHAIN TENSIONER CPL.	TENDEUR DE CHAÎNE CPL.	ENSOR DE LA CADENA CPL.
6	168	1	1	1	1	1	1	1	1	1	1	1	1	038 213 080		BUCHSE FÜR ANTRIEBSRAD		BUSHING	DOUILLE	CASQUILLO
6	169	1	1	1	1	1	1	1	1	1	1	1	1	038 213 230		FEDERSCHEIBE		SPRING WASHER	RONDELLE A RESSORT	ARANDELA ELASTICO
6	170	1	1	1	1	1	1	1	1	1	1	1	1	028 213 010		SCHEIBE	12X9	WASHER	RONDELLE	ARANDELA
6	171	1	1	1	1	1	1	1	1	1	1	1	1	957 213 040		SPANNSCHRAUBE SATZ		TENSIONING SCREW SET	VIS DE TENSION JEU	TORNILLO DE TENSION JUEGO
6	172	1	1	1	1	1	1	1	1	1	1	1	1	038 213 090		SPANNMUTTER		TENSIONING NUT	ECROU DE TENSION	TUERCA DE TENSION
6	173	1	1	1	1	1	1	1	1	1	1	1	1	038 213 070		SPANNSCHRAUBENLAGER		TENSIONING SCREW BEARING	PALIER DE LA VIS DE TENSION	SOPORTE DEL TORNILLO TENSOR
6	174	1	1	1	1	1	1	1	1	1	1	1	1	915 135 100		ZYLINDERBLECHSCHRAUBE	BZ3,5X9,5	SCREW	VIS	TORNILLO
6	175	1	1	1	1	1	1	1	1	1	1	1	1	024 213 240		KETTENFÜHRUNG		CHAIN GUIDE	GUIDE DE CHAÎNE	GUIA DE CADENA
6	176	2	2	2	2	2	2	2	2	2	2	2	2	923 208 004		6KT-MUTTER MIT BUND	M8	HEXAGONAL NUT	ECROU HEXAGONAL	TUERCA HEXAGONAL
6	177	1	1	1	1	1	1	1	1	1	1	1	1	957 250 060	ACC.	ZACKENLEISTE KETTENDECKEL KPL.		SPIKE BAR CPL.	BARRE DENTÉE CPL.	BARRA DENTADA CPL.
6	178							1	1	1	1	1	1	038 250 210		ZACKENLEISTE USA KETTENDECKEL		SPIKE BAR	BARRE DENTÉE	BARRA DENTADA
6	179	2	2	2	2	2	2	2	2	2	2	2	2	908 005 125		INNENSTERN-SCHRAUBE	M5x12	SCREW	VIS	TORNILLO
6	180	2	2	2	2	2	2	2	2	2	2	2	2	920 405 000		6KT-MUTTER	M5	HEXAGONAL NUT	ECROU HEXAGONAL	TUERCA HEXAGONAL
6	182							1						980 114 925		SCHILD KETTENSANNER	USA	LABEL	PLAQUE	CALCOMANIA
6	185	1	1	1	1	1	1	1	1	1	1	1	1	038 213 280		4KT-SCHEIBE		WASHER	RONDELLE	ARANDELA
6	186	1	1	1	1	1	1	1	1	1	1	1	1	935 940 100		ZYLINDERSTIFT	4X10	CYLINDRICAL PIN	GOUPILLE CYL.	PRISIONERO

DCS6400, DCS6401
DCS7300, DCS7301
DCS7900, DCS7901

7

Vergaser
Carburetor
Carburateur
Carburador

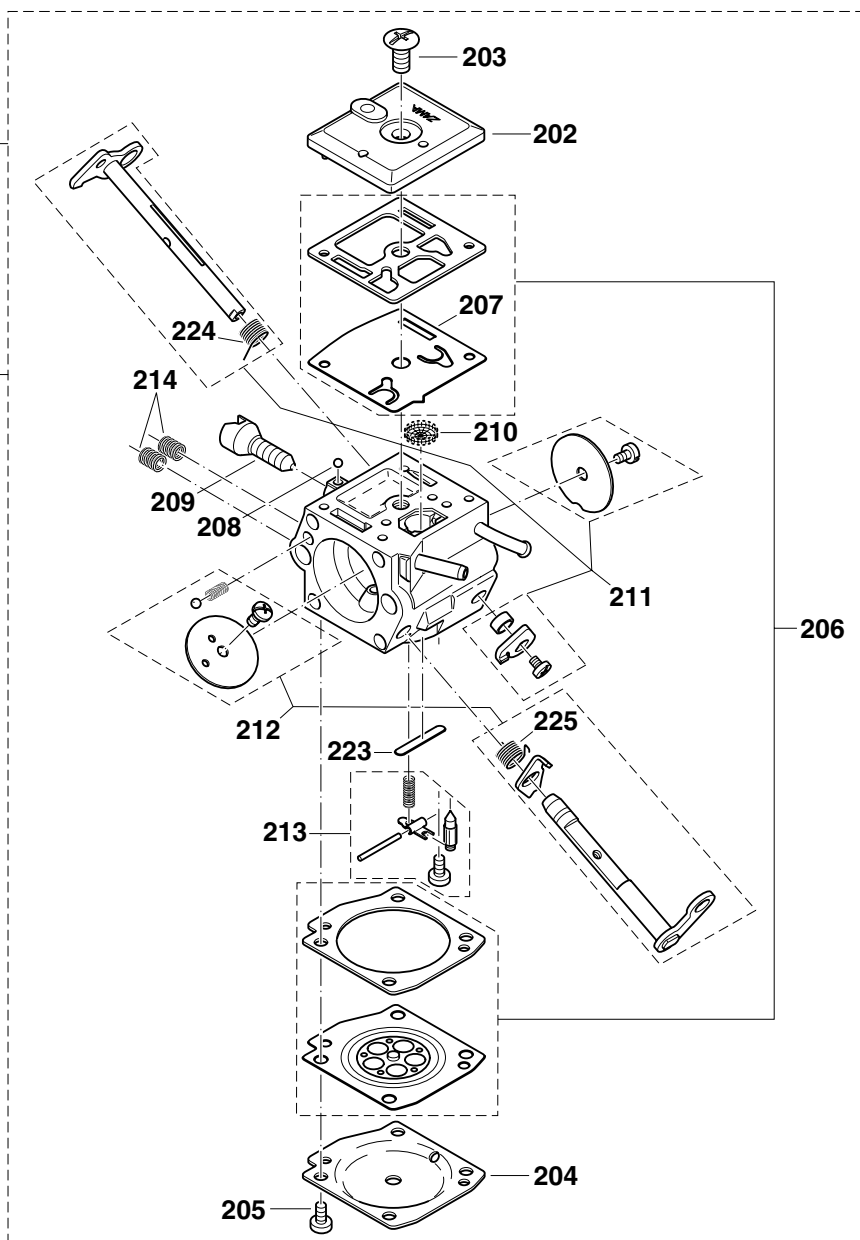
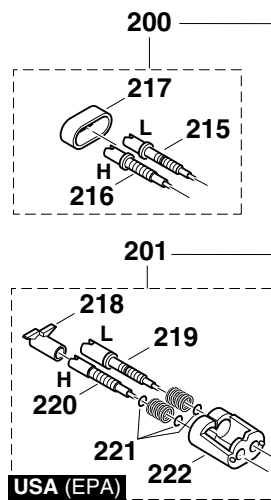

DCS 6400, 6401, 7300, 7301, 7900, 7901



Seite / Page	Pos.	DCS 6400	DCS 6401	DCS 7300	DCS 7301	DCS 7900	DCS 7901	DCS 6400 USA	DCS 6401 USA	DCS 7300 USA	DCS 7301 USA	DCS 7900 USA	DCS 7901 USA	Teil-Nr. Part No. No. de pièce No. de pieza	Hinweise Notes Renseign. Nota	Bezeichnung	Spezifikation Specification	Description	Désignation	Denominación
7	200	1	1	1	1	1	1							038 153 010		VERGASER	C3M	CARBURETOR	CARBURATEUR	CARBURADOR
7	201							1	1	1	1	1	1	038 153 020		VERGASER	C3M USA	CARBURETOR	CARBURATEUR	CARBURADOR
7	202	1	1	1	1	1	1	1	1	1	1	1	1	038 153 030		PUMPENDECKEL		PUMP COVER	COUVERCLE DE POMPE	TAPA DE BOMBA
7	203	1	1	1	1	1	1	1	1	1	1	1	1	038 153 360		SCHRAUBE		SCREW	VIS	TORNILLO
7	204	1	1	1	1	1	1	1	1	1	1	1	1	038 153 040		MEMBRANDECKEL		DIAPHRAGM COVER	COUVERCLE DE MEMBRANE	TAPA DE MEMBRANA
7	205	4	4	4	4	4	4	4	4	4	4	4	4	001 153 020		SCHRAUBE		SCREW	VIS	TORNILLO
7	206	1	1	1	1	1	1	1	1	1	1	1	1	038 153 060		DICHTUNG UND MEMBRANSATZ		SET DIAPHRAGM / GASKETS	JEU DE MEMBRANES / JOINTS	JUEGO MEMBRANAS / JUNTAS
7	207	1	1	1	1	1	1	1	1	1	1	1	1	038 153 070		PUMPENMEMBRANE, TEFLON		PUMP DIAPHRAGM TEFLON	MEMBRANE DE POMPE TEFLON	MEMBRANA DE LA BOMBA TEFLON
7	207	1	1	1	1	1	1	1	1	1	1	1	1	038 153 370	ACC.	PUMPENMEMBRANE, GUMMI		PUMP DIAPHRAGM RUBBER	MEMBRANE DE POMPE CAOUTCH.	MEMBRANA DE LA BOMBA CAUCHO
7	209	1	1	1	1	1	1	1	1	1	1	1	1	038 153 220		LEERLAUF-ANSCHLAGSCHRAUBE	S	IDLE STOP SCREW	VIS DE BUTÉE DE RALENTI	TORNILLO DE TOPE
7	210	1	1	1	1	1	1	1	1	1	1	1	1	028 153 180		SIEB		SCREEN	TAMIS	TAMIZ
7	211	1	1	1	1	1	1	1	1	1	1	1	1	957 153 060		REP.-SATZ DROSSELWELLE		KIT THROTTLE SHAFT	JEU AXE CLAPET D'ÉTRANG.	JUEGO EJE VALVULA REG.
7	212	1	1	1	1	1	1	1	1	1	1	1	1	957 153 050		REP.-SATZ CHOKEWELLE		KIT CHOKE SHAFT	JEU AXE CLAPET D'AIR	JUEGO EJE VALVULA AIRE
7	213	1	1	1	1	1	1	1	1	1	1	1	1	957 153 070		STEUERTEILE		CONTROL PARTS	PIÈCES DE COMMANDE	PIEZAS DE MANDO
7	214	2	2	2	2	2	2	2	2	2	2	2	2	038 153 260		FEDER		SPRING	RESSORT	RESORTE
7	215	1	1	1	1	1	1							038 153 230		LEERLAUF-STELLSCHRAUBE	L	IDLE ADJUSTMENT SCREW	VIS DE RÉGL. DE RALENTI	TORNILLO REGULADOR
7	216	1	1	1	1	1	1							038 153 240		VOLLGAS-STELLSCHRAUBE	H	MAIN ADJUSTMENT SCREW	VIS DE RÉGL. PLEIN GAZ	TORNILLO REGULADOR
7	217	1	1	1	1	1	1							038 153 270		GUMMIRING		RUBBER RING	RONDELLE DE CAOUTCHOU	ARANDELA DE GOMA
7	218							1	1	1	1	1	1	038 153 310		LIMITER CAP	USA/EPA	LIMITER CAP	CAPUCHON LIMITEUR	CAPUCHONE LIMITADORE
7	219							1	1	1	1	1	1	038 153 290		LEERLAUF-STELLSCHRAUBE	L - USA/EPA	IDLE ADJUSTMENT SCREW	VIS DE RÉGL. DE RALENTI	TORNILLO REGULADOR
7	220							1	1	1	1	1	1	038 153 300		VOLLGAS-STELLSCHRAUBE	H - USA/EPA	MAIN ADJUSTMENT SCREW	VIS DE RÉGL. PLEIN GAZ	TORNILLO REGULADOR
7	221							3	3	3	3	3	3	038 153 250		SCHEIBE	USA/EPA	WASHER	RONDELLE	ARANDELA
7	222							1	1	1	1	1	1	038 153 320		EINSTELLFÜHRUNG	USA/EPA	ADJUSTING GUIDE	GUIDAGE D' AJUSTAGE	GUÍA DE AJUSTE
7	223	1	1	1	1	1	1	1	1	1	1	1	1	038 153 350		VERSCHLUßSCHEIBE		PLUG-WELCH	RONDELLE DE FERMETURE	DISCO DE CIERRE
7	224	1	1	1	1	1	1	1	1	1	1	1	1	038 153 150		DREHFEDER FÜR DROSSELKLAPPE		SPRING	RESSORT	RESORTE
7	225	1	1	1	1	1	1	1	1	1	1	1	1	038 153 100		DREHFEDER		SPRING	RESSORT	RESORTE

DCS6400, DCS6401
DCS7300, DCS7301
DCS7900, DCS7901

8

Spezialteile für Ausrüstung mit elektrischer Griffheizung
Special parts for version with electric handle heating
Pièces spéciales pour version avec chauffage de la poignée (électrique)
Piezas especiales po tipo con calefacción eléctrica de mango

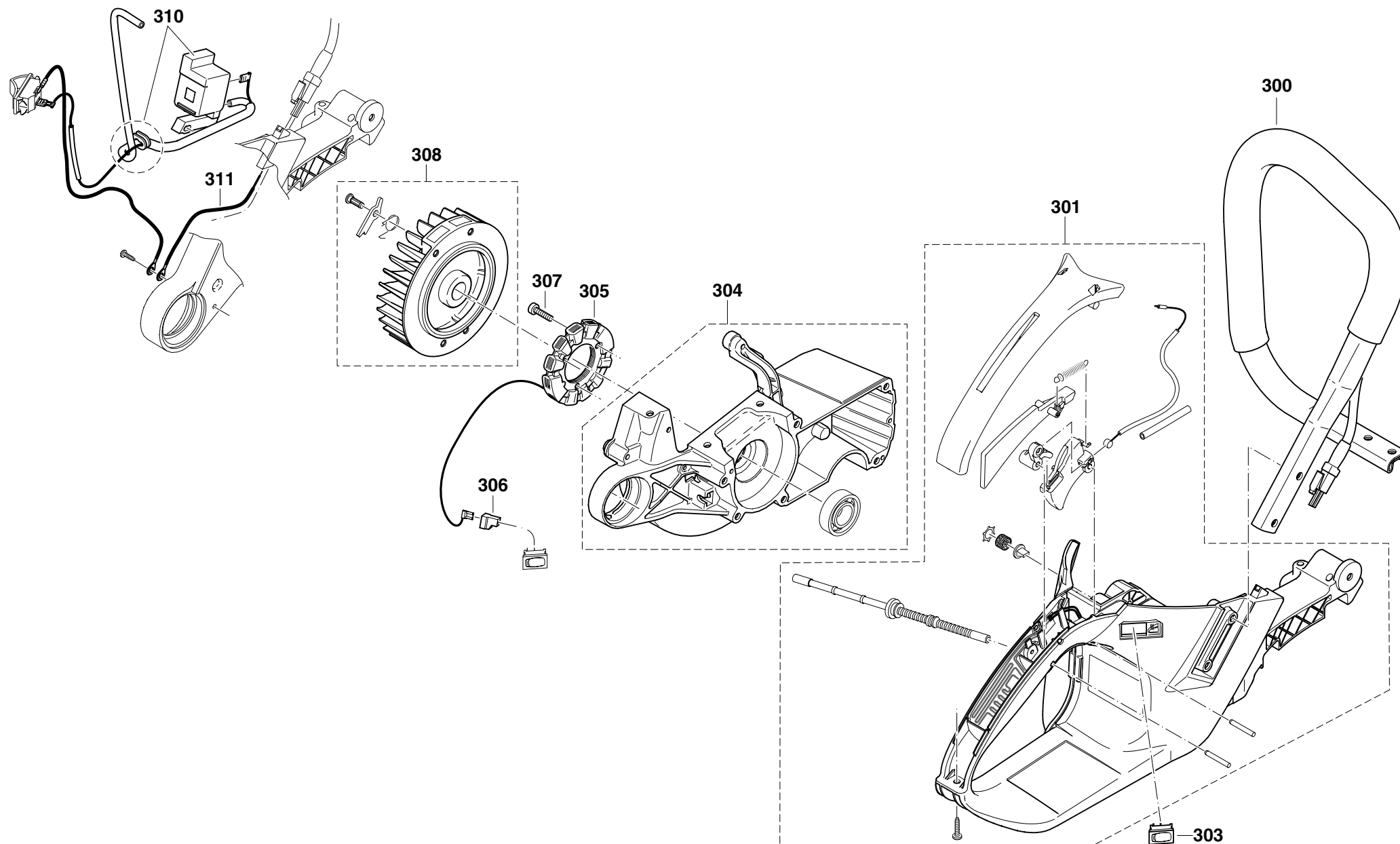

DCS 6400, 6401, 7300, 7301, 7900, 7901



Seite / Page	Pos.	DCS 6400	DCS 6401	DCS 7300	DCS 7301	DCS 7900	DCS 7901	DCS 6400 USA	DCS 6401 USA	DCS 7300 USA	DCS 7301 USA	DCS 7900 USA	DCS 7901 USA	Teil-Nr. Part No. No. de pièce No. de pieza	Hinweise Notes Renseign. Nota	Bezeichnung	Spezifikation Specification	Description	Désignation	Denominación
8	300	1	1	1	1	1	1	1	1	1	1	1	1	038 310 030		BÜGELGRIFF KPL. (HEIZUNG)		TUBULAR HANDLE ASSY.	POIGNÉE TUBULAIRE CPL.	MANGO TUBULAR CPL.
8	301	1	1	1	1	1	1	1	1	1	1	1	1	038 114 670		TANK KPL. BLAU (HEIZ. UNGEREGELT)		TANK CPL. BLUE	RÉSERVOIR CPL. BLEU	DEPÓSITO CPL. AZUL
8	303	1	1	1	1	1	1	1	1	1	1	1	1	975 001 250		SCHALTER		SWITCH	INTERRUPTEUR	INTERRUPTOR
8	304	1	1	1	1	1	1	1	1	1	1	1	1	038 111 660		KURBELGEHÄUSE MS BLAU		CRANKC. MAG. SIDE BLUE	CARTER-COTÉ MAGN. BLEU	CÁRTER CIG. LADO MAG. AZUL
8	305	1	1	1	1	1	1	1	1	1	1	1	1	038 148 020		GENERATORANKER KPL.		GENERATOR COIL	BOBINE GÉNÉRATRICE	BOBINA GENERADOR
8	306	1	1	1	1	1	1	1	1	1	1	1	1	038 146 030		ISOLIERKAPPE		INSULATING CAP	CHAPE D'ISOLATION	CUBIERTO DE AISLADOR
8	307	3	3	3	3	3	3	3	3	3	3	3	3	913 340 204		INNENSTERN-SCHLITZ-SCHRAUBE	4X20	SCREW	VIS	TORNILLO
8	308	1	1	1	1	1	1	1	1	1	1	1	1	038 148 000		POLRAD KPL. (HEIZUNG UNGEREGELT)		FLYWHEEL ASSY.	ROUE POLAIRE CPL.	VOLANTE ENCENDIDO
8	310	1	1	1	1	1	1	1	1	1	1	1	1	038 143 040		ZÜNDSPULE KPL. WEINROT		IGNITION COIL RED	BOBINE D' ALLUMAGE ROUGE	BOBINA ENCENDIDO ROJO
8	311	1	1	1	1	1	1	1	1	1	1	1	1	970 311 570		MASSELEITUNG		EARTH CABLE	FIL DE MASSE	CONDUCCIÓN A MASA

DCS6400, DCS6401
DCS7300, DCS7301
DCS7900, DCS7901

9

Sägeschiener, Sägeketten, Werkzeug
Guide bars, saw chains, tools
Guide-chaîne et chaînes, outils
Rieles guía, cadenas sierra, herramientas

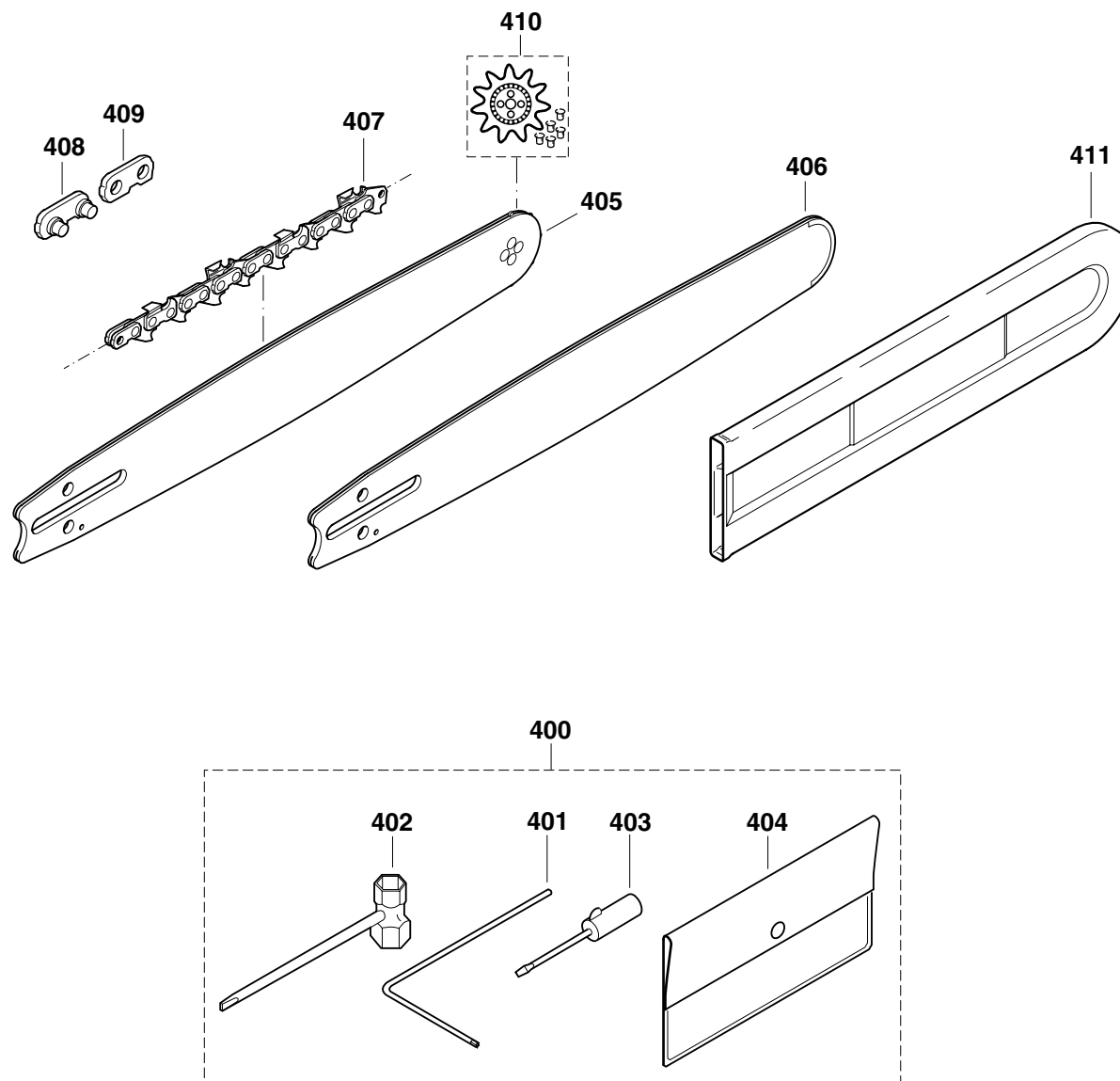

DCS 6400, 6401, 7300, 7301, 7900, 7901



Seite / Page	Pos.	DCS 6400	DCS 6401	DCS 7300	DCS 7301	DCS 7900	DCS 7901	DCS 6400 USA	DCS 6401 USA	DCS 7300 USA	DCS 7301 USA	DCS 7900 USA	DCS 7901 USA	Teil-Nr. Part No. No. de pièce No. de pieza	Hinweise Notes Renseign. Nota	Bezeichnung	Spezifikation Specification	Description	Désignation	Denominación
9	400	1	1	1	1	1	1	1	1	1	1	1	1	957 004 002		WERKZEUG KPL.		TOOL CPL.	OUTILS CPL.	HERRAMIENTAS CPL.
9	401	1	1	1	1	1	1	1	1	1	1	1	1	940 827 000		WINKELSCHRAUBENDREHER	T27	ANGLED SCREW DRIVER	CLÉ ANGLE	LLAVE ANGULAR
9	402	1	1	1	1	1	1	1	1	1	1	1	1	941 719 131		KOMBISCHLÜSSEL	19/13	UNIVERSAL WRENCH	CLÉ COMBINÉE	LLAVE DE BUJÍA
9	403	1	1	1	1	1	1	1	1	1	1	1	1	944 340 001		SCHRAUBENDREHER ROT		SCREW DRIVER	TOURNEVIS	DESTORNILLADOR
9	404	1	1	1	1	1	1	1	1	1	1	1	1	950 004 001		WERKZEUGTASCHE NEUTRAL		PLASTIC BAG	POCHETTE EN PLASTIQUE	CARTERA HERRAMIENTAS
9	405	1	1	1	1	1	1	1	1	1	1	1	1	445 035 655		STERNSCHIENE	3/8" .058" 35CM-14"	SPROCKET NOSE BAR	GUIDE À ÉTOILE	GUÍA CON ESTRELLA
9	405	1	1	1	1	1	1	1	1	1	1	1	1	445 038 655		STERNSCHIENE	3/8" .058" 38CM-15"	SPROCKET NOSE BAR	GUIDE À ÉTOILE	GUÍA CON ESTRELLA
9	405	1	1	1	1	1	1	1	1	1	1	1	1	445 045 655		STERNSCHIENE	3/8" .058" 45CM-18"	SPROCKET NOSE BAR	GUIDE À ÉTOILE	GUÍA CON ESTRELLA
9	405	1	1	1	1	1	1	1	1	1	1	1	1	445 050 655		STERNSCHIENE	3/8" .058" 50CM-20"	SPROCKET NOSE BAR	GUIDE À ÉTOILE	GUÍA CON ESTRELLA
9	405							1	1	1	1	1	1	445 050 665		STERNSCHIENE U.S.A.	3/8" .050" 50CM-20"	SPROCKET NOSE BAR U.S.A.	GUIDE À ÉTOILE	GUÍA CON ESTRELLA
9	405	1	1	1	1	1	1	1	1	1	1	1	1	445 060 655		STERNSCHIENE	3/8" .058" 60CM-24"	SPROCKET NOSE BAR	GUIDE À ÉTOILE	GUÍA CON ESTRELLA
9	406	1	1	1	1	1	1	1	1	1	1	1	1	445 045 455		PANZERSCHIENE	3/8" .058" 45CM-18"	SOLID NOSE BAR	GUIDE BLINDÉ	GUÍA BLINDADA
9	406	1	1	1	1	1	1	1	1	1	1	1	1	445 050 455		PANZERSCHIENE	3/8" .058" 50CM-20"	SOLID NOSE BAR	GUIDE BLINDÉ	GUÍA BLINDADA
9	406	1	1	1	1	1	1	1	1	1	1	1	1	445 060 455	Ti 2001/16	PANZERSCHIENE	3/8" .058" 60CM-24"	SOLID NOSE BAR	GUIDE BLINDÉ	GUÍA BLINDADA
9	406	1	1	1	1	1	1	1	1	1	1	1	1	445 070 455		PANZERSCHIENE	3/8" .058" 70CM-28"	SOLID NOSE BAR	GUIDE BLINDÉ	GUÍA BLINDADA
9	407	1	1	1	1	1	1	1	1	1	1	1	1	528 099 656		SÄGEKETTE	3/8" .058" 35CM-14"	SAW CHAIN	CHAÎNE	CADENA
9	407	1	1	1	1	1	1	1	1	1	1	1	1	528 099 660		SÄGEKETTE	3/8" .058" 38CM-15"	SAW CHAIN	CHAÎNE	CADENA
9	407	1	1	1	1	1	1	1	1	1	1	1	1	528 099 668		SÄGEKETTE	3/8" .058" 45CM-18"	SAW CHAIN	CHAÎNE	CADENA
9	407	1	1	1	1	1	1	1	1	1	1	1	1	528 099 672		SÄGEKETTE	3/8" .058" 50CM-20"	SAW CHAIN	CHAÎNE	CADENA
9	407							1	1	1	1	1	1	513 496 672		SÄGEKETTE U.S.A.	3/8" .050" 50CM-20"	SAW CHAIN U.S.A.	CHAÎNE	CADENA
9	407	1	1	1	1	1	1	1	1	1	1	1	1	528 099 684	Ti 2001/16	SÄGEKETTE	3/8" .058" 60CM-24"	SAW CHAIN	CHAÎNE	CADENA
9	407	1	1	1	1	1	1	1	1	1	1	1	1	528 099 694		SÄGEKETTE	3/8" .058" 70CM-28"	SAW CHAIN	CHAÎNE	CADENA
9	408	1	1	1	1	1	1	1	1	1	1	1	1	558 093 010		AUßENLASCHE MIT NIET	3/8" .058"	TIE STRAP WITH RIVETS	ECLISSE AVEC RIVETS	TIRA EXT. CON REMACHES
9	409	1	1	1	1	1	1	1	1	1	1	1	1	558 093 000		AUßENLASCHE	3/8" .058"	TIE STRAP	ECLISSE EXTERIEURE	TIRA EXT.
9	410	1	1	1	1	1	1	1	1	1	1	1	1	415 038 720		UMLENKSTERN KPL.	3/8" .058"	SPROCKET NOSE	ÉTOILE	ESTRELLA
9	411	1	1	1	1	1	1	1	1	1	1	1	1	952 100 643		KETTENSCHUTZ SCHWARZ	38-45CM, 15"-18"	CHAIN PROTECTION	PROTECTION CHAÎNE	PROTECTOR DE CADENA
9	411	1	1	1	1	1	1	1	1	1	1	1	1	952 100 653		KETTENSCHUTZ SCHWARZ	50-60CM, 20"-24"	CHAIN PROTECTION	PROTECTION CHAÎNE	PROTECTOR DE CADENA
9	411	1	1	1	1	1	1	1	1	1	1	1	1	952 100 171		KETTENSCHUTZ ROT	70CM, 28"	CHAIN PROTECTION	PROTECTION CHAÎNE	PROTECTOR DE CADENA

DCS6400, DCS6401
DCS7300, DCS7301
DCS7900, DCS7901

Inhaltsverzeichnis
Index
Table des matières
Indice



1	Kraftstofftank, Bügelgriff	Fuel tank, tubular grip	Réserv. carburant, poignée tubulaire	Depósito de combustible, mango tubular
2	Abdeckhaube, Luftfilter, Schalldämpfer	Hood, air filter, muffler	Capot protecteur, filtre à air, pot d'échappement	Cubierta protectora, filtro de aire, silencioso
3	Zylinder, Kurbelgehäuse	Cylinder, crankcase	Cylindre, carter- vilebrequin	Cilíndro, carter cigüeñal
4	Zündelektronik, Anwerfvorrichtung	Ignition electronics, starter	Allumage électronique, dispositif de démarrage	Bobina encendido, dispositivo de arranque
5	Ölpumpe, Kupplung	Oil pump, clutch	Pompe à huile, embrayage	Bomba de aceite, embrague
6	Kettenbremse	Chain brake	Frein de chaîne	Freno de cadena
7	Vergaser	Carburetor	Carburetur	Carburador
8	Spezialteile für Ausrüstung mit elektrischer Griffheizung	Special parts for version with electric handle heating	Pièces spéciales pour version avec chauffage de la poignée (électrique)	Piezas especiales po tipo con calefacción eléctric de mango
9	Sägeschienen, Sägeketten, Werkzeug	Guide bars, saw chains, tools	Guide-chaîne et chaînes, outils	Rieles guía, cadenas sierra, herramientas

	Zeichenerklärung (D)	Key to symbols (GB)	Légende (F)	Explicación de símbolos (E)
<p>⇒ 1999999 2000000 ⇒ 2003.04 ⇒ TI 2003/07 Acc. = { m Corr.</p>	<p>Produktion bis Serien-Nr. Neues Teil ab Serien-Nr. Neues Teil ab Jahr / Monat Siehe Technische Information Jahr / Nr. Zubehör (nicht im Lieferumfang) Keine Serienausführung, jedoch verwendbar Beinhaltet Positions-Nr. Meterware Druckfehlerberichtigung</p>	<p>Production to serial number New part from serial number New part from Year / Month See Technical Information Year / No. Accessories (not included in the delivery inventory) No standard execution, may be used Contains item number Sold by the meter Error correction</p>	<p>Production jusqu'à n° de série Nouveau pièce à partir du n° de série Nouveau pièce à partir de année / mois Voir information technique année / n° Accessoires (non compris dans la livraison) Aucune exécut. en série, cependant utilisable contient n° de numéro Au mètre Rectification d'erreurs</p>	<p>Producción hasta N° de serie Pieza nueva a partir de N° de serie Pieza nueva a partir de año / mes Véase inform. técnico año / N° Accesorios (no incluido en la extensión del suministro) No es de serie, pero sirve Contiene pos N° Por metro Fe de erratas</p>
	Verklaring der tekens (NL)	Chiarificazione dei simboli (I)	Objasnitev znakov (SLO)	Επεξήγηση συμβόλων (GR)
<p>⇒ 1999999 2000000 ⇒ 2003.04 ⇒ TI 2003/07 Acc. = { m Corr.</p>	<p>In productie tot serie-Nr. Nieuw onderdeel vanaf serie-Nr. Nieuw onderdeel vanaf jaar / maand Zie technische informatie jaar / Nr. Accessoires (niet meegeleverd) Geen serieuitvoering, maar wel bruikbaar Omvat Positie-Nr. Metergoed Drukfoutcorrectie</p>	<p>Produzione fino al n. di serie Nuovo pezzo a partire dal n. di serie Nuovo pezzo a partire dal anno / mese Vedere il inform. tecnici del anno / n. Accessori (non compresi nell'insieme di forniture) Non è un modello di serie, ma ugualm. utilizza. Comprende la posizione n. Articoli a metraggio Rettifica di errori di stampa</p>	<p>Produkcija do serijske številke Novi del od serijske številke dalje Novi del od leta / meseca dalje Glej tehnične informacije od leta / številke. Pritikline (niso v obsegu dostave) Ni serijska izvedba, a uporabno Vsebuje pozicijsko število. Metrsko blago Popravek tiskovnih napak</p>	<p>Παραγωγή μέχρι τον αριθμό σειράς Νέο εξάρτημα από τον αριθμό σειράς Νέο εξάρτημα από το έτος / μήνα Βλέπε πληροφορίες του τεχνικά το έτος / αριθμό Πρόσθετα εξαρτήματα (δεν ανήκουν στη συσκευασία παράδοσης) Δεν έχει εκδοθεί σε σειρά, αλλά χρησιμοποιείται Περιλαμβάνει τον αριθμό θέσης Εμπόρευμα με το μέτρο Διόρθωση λάθους πίεσης</p>